

INSTALLER: LEAVE THIS MANUAL WITH THE APPLIANCE.
 CONSUMER: RETAIN THIS MANUAL FOR FUTURE REFERENCE.
 NEVER LEAVE CHILDREN OR OTHER AT RISK INDIVIDUALS ALONE WITH THE APPLIANCE.

EN



INSTALLATION AND OPERATING INSTRUCTIONS

FR
PG
73

CERTIFIED TO CANADIAN AND AMERICAN NATIONAL STANDARDS: CSA 2.22 AND ANSI Z21.50, FOR VENTED DECORATIVE GAS APPLIANCES.

FOR INDOOR USE ONLY

SAFETY INFORMATION

! WARNING

If the information in these instructions are not followed exactly, a fire or explosion may result causing property damage, personal injury or loss of life.

- Do not store or use gasoline or other flammable vapors and liquids in the vicinity of this or any other appliance.
- **WHAT TO DO IF YOU SMELL GAS:**
 - Do not try to light any appliance.
 - Do not touch any electrical switch; do not use any phone in your building.
 - Immediately call your gas supplier from a neighbour's phone. Follow the gas supplier's instructions.
 - If you cannot reach your gas supplier, call the fire department.
- Installation and service must be performed by a qualified installer, service agency or the supplier.

This appliance may be installed in an aftermarket, permanently located, manufactured home (USA only) or mobile home, where not prohibited by local codes.

This appliance is only for use with the type of gas indicated on the rating plate. This appliance is not convertible for use with other gases, unless a certified kit is used.

**CB36NTR / CB36NTRE &
 CX36NTR-1 / GCX36NTRE-1**
 NATURAL GAS MODEL

**CB36PTR / CB36PTRE &
 CX36PTR-1 / CX36PTRE-1**
 PROPANE GAS MODEL

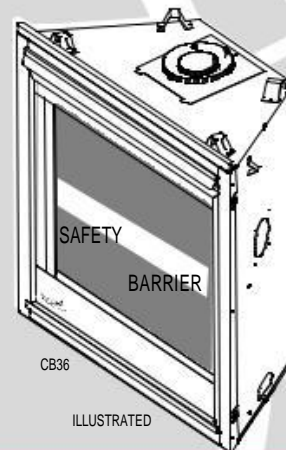

! DANGER

HOT GLASS WILL CAUSE BURNS.
DO NOT TOUCH GLASS UNTIL COOLED.
NEVER ALLOW CHILDREN TO TOUCH GLASS.

A barrier designed to reduce the risk of burns from the hot viewing glass is provided with this appliance and shall be installed for the protection of children and other at-risk individuals.



Wolf Steel Ltd., 24 Napoleon Rd., Barrie, ON, L4M 0G8 Canada / 103 Miller Drive,
 Crittenden, Kentucky, USA, 41030 Phone 1 (866) 820-8686 www.continentalfireplaces.com
ask@continentalfireplaces.com

table of contents

EN



NOTE: The camera icon indicates video tutorials are available as additional reference.

Visit <http://mynapoleon.napoleonproducts.com/download/index/44/1>

1.0	installation overview	3	6.0	finishing	45
2.0	introduction	4	6.1	safety barrier & door removal / installation	45
2.1	dimensions for CB36 / CX36-1	5	6.2	front hood installation	46
2.2	general instructions	6	6.3	CB36 / CX36-1 log placement	47
2.3	general information	7	6.4	charcoal embers	48
2.4	rating plate information	8	6.5	glowing embers	48
3.0	venting	9	6.6	battery back-up installation	48
3.1	venting lengths and components	10		wiring diagram	49
3.2	typical vent installation	11	7.0	wiring requirements for CB36 / CX36-1	49
3.3	special vent installations	13	7.1	CB36 electronic wiring diagram	49
3.3.1	periscope termination	13	7.2	CX36-1 electronic wiring diagram	50
3.3.2	corner termination	13	8.0	operation (electronic)	51
3.4	minimum air terminal location clearances	14	9.0	operation (millivolt)	52
3.5	venting application flow chart	15	adjustment	53	
3.6	definitions	16	10.1	pilot burner adjustment	53
3.7	elbow vent length values	16	10.2	venturi adjustment	53
3.8	top exit horizontal termination	17	10.3	flame characteristics	54
3.9	rear exit horizontal termination	19	10.4	optional anti-condensation switch (models CB36NTRE/CB36PTRE/ CX36NTRE-1 & CX36PTRE-1 only)	54
3.10	top and rear exit vertical termination	21		maintenance	55
3.11	rear exit	23	11.1	annual maintenance	56
3.12	rear exit shield (for rear vent only)	23	11.2	door glass replacement	56
3.13	top exit	24	11.3	care of glass	57
4.0	installation	25		replacements	57
4.1	wall and ceiling protection	25	12.1	CB36 overview	58
4.1.1	horizontal installation	26	12.2	CB36 millivolt valve assembly	59
4.1.2	vertical installation	26	12.3	CB36 electronic valve assembly	60
4.2	using flexible vent components	26	12.4	CX36-1 overview	61
4.2.1	horizontal air terminal installation	27	12.5	CX36-1 millivolt valve assembly	62
4.2.2	vertical air terminal installation	27	12.6	CX36-1 electronic valve assembly	63
4.2.3	appliance vent connection	28		CB36 accessories	64
4.3	using rigid vent components	29		CX36-1 accessories	65
4.3.1	horizontal air terminal installation	29		CX36-1 accessories (page 2)	66
4.3.2	vertical air terminal installation	29		troubleshooting (electronic)	67
4.3.3	restricting vertical vents	30	13.0	troubleshooting (millivolt)	69
4.4	vertical through existing chimney	31		warranty	71
4.5	mobile home installation	32			
4.6	gas installation	32			
4.7	optional wall switch	32			
5.0	framing	34	14.0		
5.1	framing for CB36 / CX36-1	34	15.0		
5.1.1	minimum framing dimensions for CB36 / CX36-1	34	16.0		
5.2	minimum enclosure clearances	35			
5.3	non-combustible facing material for CB36 / CX36-1	35			
5.4	alcove clearances	36			
5.5	recessed installation	36			
5.6	minimum mantel clearances	38			
5.7	nailing tab installation	42			
		42			
		43			
		44			
		44			

NOTE: Changes, other than editorial, are denoted by a vertical line in the margin.

1.0 installation overview

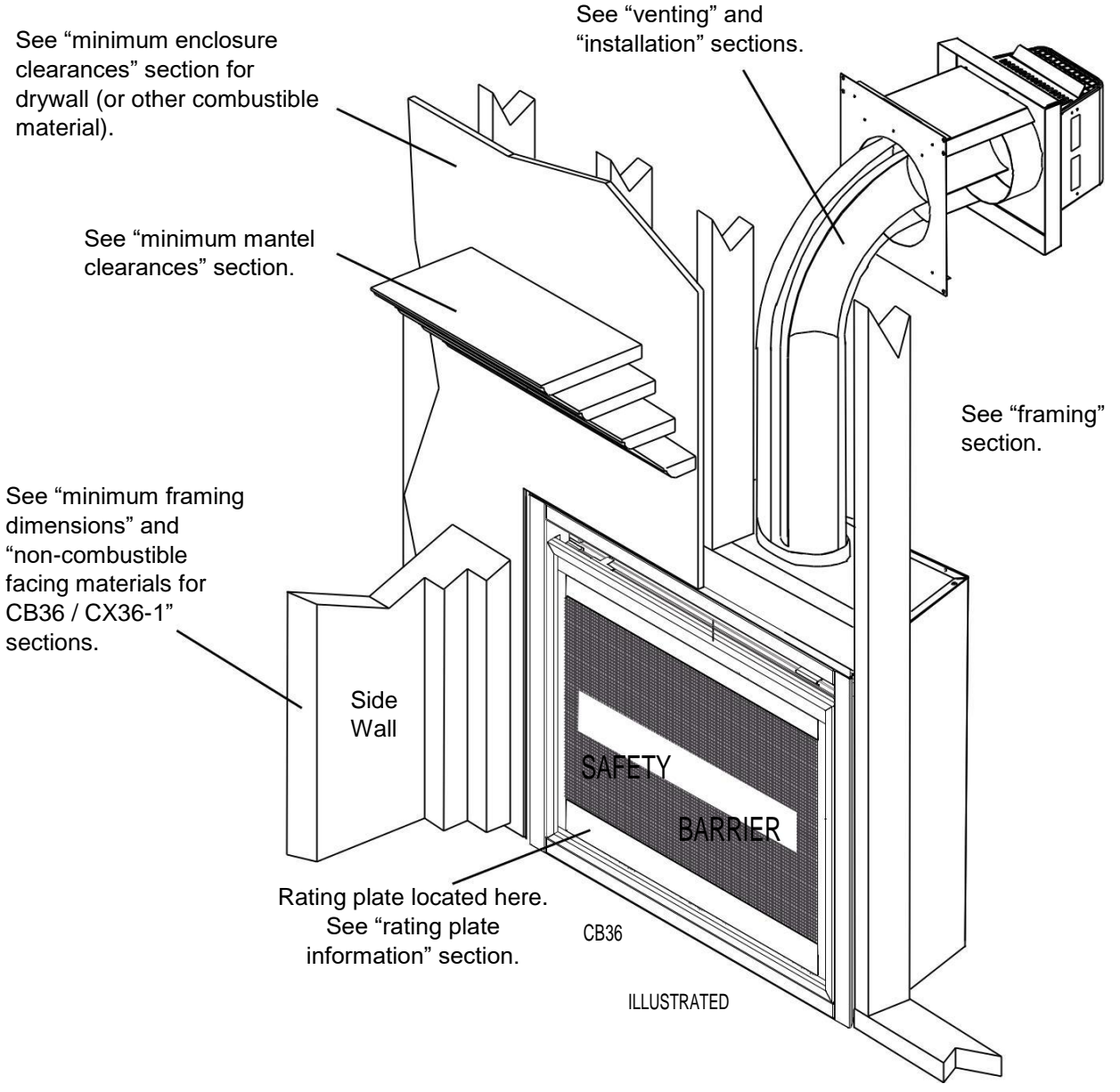

Batteries must be disposed of according to the local laws and regulations. Some batteries may be recycled, and may be accepted for disposal at your local recycling center. Check with your municipality for recycling instructions.

2.0 introduction

EN

!WARNING

- **THIS APPLIANCE IS HOT WHEN OPERATED AND CAN CAUSE SEVERE BURNS IF CONTACTED.**
- **ANY CHANGES TO THIS APPLIANCE OR ITS CONTROLS CAN BE DANGEROUS AND ARE PROHIBITED.**
- Do not operate appliance before reading and understanding operating instructions. Failure to operate appliance according to operating instructions could cause fire or injury.
- Risk of fire or asphyxiation do not operate appliance with fixed glass removed.
- Do not connect 110 volts to the control valve.
- Risk of burns. The appliance should be turned off and cooled before servicing.
- Do not install damaged, incomplete or substitute components.
- Risk of cuts and abrasions. Wear protective footwear, gloves and safety glasses during installation. Sheet metal edges may be sharp.
- **Children and adults should be alerted to the hazards of high surface temperature and should stay away to avoid burns or clothing ignition.**
- **Young children should be carefully supervised when they are in the same room as the appliance. Toddlers, young children and others may be susceptible to accidental contact burns. A physical barrier is recommended if there are at risk individuals in the house. To restrict access to an appliance or stove, install an adjustable safety gate to keep toddlers, young children and other at risk individuals out of the room and away from hot surfaces.**
- **Clothing or other flammable material should not be placed on or near the appliance.**
- **Due to high temperatures, the appliance should be located out of traffic and away from furniture and draperies.**
- Ensure you have incorporated adequate safety measure to protect infants/toddlers from touching hot surfaces.
- Even after the appliance is out, the glass and/or screen will remain hot for an extended period of time.
- Check with your local hearth specialty dealer for safety screens and hearth guards to protect children from hot surfaces. These screens and guards must be fastened to the floor.
- **Any safety screen, guard or barrier removed for servicing the appliance, must be replaced prior to operating the appliance.**
- The appliance is a vented gas-fired appliance. Do not burn wood or other materials in the appliance.
- The appliance area must be kept clear and free from combustible materials, gasoline and other flammable vapors and liquids.
- Under no circumstances should this appliance be modified.
- This appliance must not be connected to a chimney flue pipe serving a separate solid fuel burning appliance.
- Do not use this appliance if any part has been under water. Immediately call a qualified service technician to inspect the appliance and to replace any part of the control system and any gas control which has been under water.
- Do not operate the appliance with the glass door removed, cracked or broken. Replacement of the glass should be done by a licensed or qualified service person.
- Do not strike or slam shut the appliance glass door.
- When equipped with pressure relief doors, they must be kept closed while the appliance is operating to prevent exhaust fumes containing carbon monoxide, from entering into the home. Temperatures of the exhaust escaping through these openings can also cause the surrounding combustible materials to overheat and catch fire.
- **Only doors / optional fronts certified with the unit are to be installed on the appliance.**
- Keep the packaging material out of reach of children and dispose of the material in a safe manner. As with all plastic bags, these are not toys and should be kept away from children and infants.
- As with any combustion appliance, we recommend having a Carbon Monoxide Detector installed in the same area to defend you and your family against Carbon Monoxide.
- Ensure clearances to combustibles are maintained when building a mantel or shelves above the appliance. Elevated temperatures on the wall or in the air above the appliance can cause melting, discolouration or damage to decorations, a T.V. or other electronic components.
- **A barrier designed to reduce the risk of burns from the hot viewing glass is provided with this appliance or sold as a mandatory option and shall be installed.**
- **If the barrier becomes damaged, the barrier shall be replaced with the manufacturer's barrier for this appliance.**
- **Installation and repair should be done by a qualified service person. The appliance should be inspected before use and at least annually by a professional service person. More frequent cleaning may be required due to excessive lint from carpeting, bedding material, etc. It is imperative that control compartments, burners and circulating air passageways of the appliance be kept clean.**
- The millivolt version of this appliance uses and requires a fast acting thermocouple. Replace only with a fast acting thermocouple supplied by Wolf Steel Ltd.

2.1 dimensions for CB36 / CX36-1

FRONT VIEW

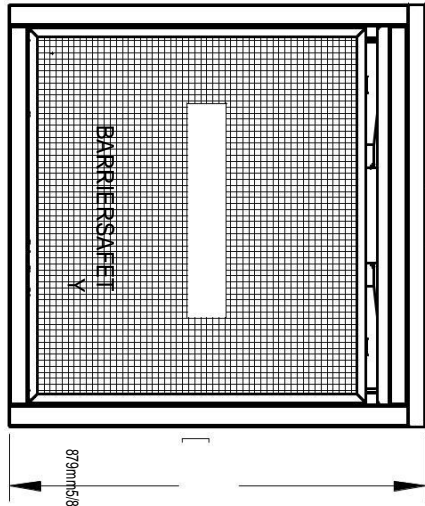

870mm/58"34"

552" 6 1 2

SIDE VIEW

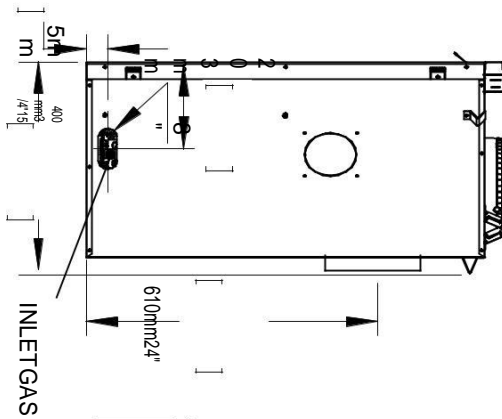

610mm/24"

514

m

400

14"15"

INLET GAS

VIEWT
OP

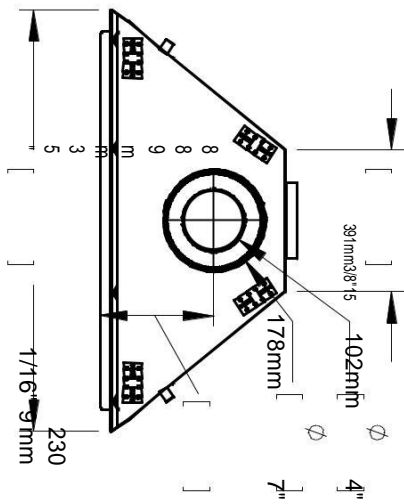

391mm/3"15"

102mm

178mm

4"

7"

3"

230

1716"97mm

2.2 general instructions

EN

! WARNING	
	ALWAYS LIGHT THE PILOT WHETHER FOR THE FIRST TIME OR IF THE GAS SUPPLY HAS RUN OUT, WITH THE GLASS DOOR OPENED OR REMOVED.
	PROVIDE ADEQUATE CLEARANCE FOR SERVICING AND OPERATING THE APPLIANCE.
	PROVIDE ADEQUATE VENTILATION.
	NEVER OBSTRUCT THE FRONT OPENING OF THE APPLIANCE.
	OBJECTS PLACED IN FRONT OF THE APPLIANCE MUST BE KEPT A MINIMUM OF 48 INCHES (121.9cm) FROM THE FRONT FACE OF THE APPLIANCE.
	SURFACES AROUND AND ESPECIALLY ABOVE THE APPLIANCE CAN BECOME HOT. AVOID CONTACT WHEN THE APPLIANCE IS OPERATING.
	FIRE RISK. EXPLOSION HAZARD.
HIGH	PRESSURE WILL DAMAGE VALVE. DISCONNECT GAS SUPPLY PIPING BEFORE PRESSURE TESTING GAS LINE AT TEST PRESSURES ABOVE 1/2 PSIG. CLOSE THE MANUAL SHUT-OFF VALVE BEFORE PRESSURE TESTING GAS LINE AT TEST PRESSURES EQUAL TO OR LESS THAN 1/2 PSIG (35mb).
	USE ONLY WOLF STEEL APPROVED OPTIONAL ACCESSORIES AND REPLACEMENT PARTS WITH THIS APPLIANCE. USING NON-LISTED ACCESSORIES (BLOWERS, DOORS, LOUVRES, TRIMS, GAS COMPONENTS, VENTING COMPONENTS, ETC.) COULD RESULT IN A SAFETY HAZARD AND WILL VOID THE WARRANTY AND CERTIFICATION.
	THE APPLIANCE MUST NOT BE OPERATED AT TEMPERATURES BELOW FREEZING (32°F / 0°C). ALLOW THE APPLIANCE TO WARM TO ABOVE FREEZING PRIOR TO OPERATION.

THIS GAS APPLIANCE SHOULD BE INSTALLED AND SERVICED BY A QUALIFIED INSTALLER to conform with local codes. Installation practices vary from region to region and it is important to know the specifics that apply to your area, for example in Massachusetts State:

This product must be installed by a licensed plumber or gas fitter when installed within the commonwealth of Massachusetts.

The appliance damper must be removed or welded in the open position prior to installation of an appliance insert or gas log.

The appliance off valve must be a "T" handle gas cock.

The flexible connector must not be longer than 3 feet (91.4cm).

A Carbon Monoxide detector is required in all rooms containing gas fired appliances.

The appliance is not approved for installation in a bedroom or bathroom unless the unit is a direct vent sealed combustion product.

The installation must conform with local codes or, in absence of local codes, the National Gas and Propane Installation Code CSA B149.1 in Canada, or the National Fuel Gas Code, ANSI Z223.1 / NFPA 54 in the United States. Suitable for mobile home installation if installed in accordance with the current standard CAN/CSA Z240MH Series, for gas equipped mobile homes, in Canada or ANSI Z223.1 and NFPA 54 in the United States.

As long as the required clearance to combustibles is maintained, the most desirable and beneficial location for an appliance is in the center of a building, thereby allowing the most efficient use of the heat created. The location of windows, doors and the traffic flow in the room where the appliance is to be located should be considered. If possible, you should choose a location where the vent will pass through the house without cutting a floor or roof joist.

If the appliance is installed directly on carpeting, vinyl tile or other combustible material other than wood flooring, the appliance shall be installed on a metal or wood panel extending the full width and depth.

Some appliances have optional fans or blowers. If an optional fan or blower is installed, the junction box must be electrically connected and grounded in accordance with local codes, use the current CSA C22.1 Canadian Electrical Code in Canada or the ANSI/NFPA 70 National Electrical code in the United States.



We suggest that our gas hearth products be installed and serviced by professionals who are certified in the U.S. by the National Fireplace Institute® (NFI) as NFI Gas Specialists

2.3 general information

For your satisfaction, this appliance has been test-fired to assure its operation and quality.

	RATES AND EFFICIENCIES			
	CB36		CX36-1	
	NG	P	NG	P
Altitude (FT)	0-4,500	0-4500	0-4,500	0-4,500
Max. Input (BTU/HR)	18,000	18,000	25,000	25,000
Min. Inlet Gas Supply Pressure	4.5" (11mb) w.c.	11" (27mb) w.c.	4.5" (11mb) w.c.	11" (27mb) w.c.
Max. Inlet Gas Supply Pressure	13" (32mb) w.c.	13" (32mb) w.c.	13" (17mb) w.c.	13" (32mb) w.c.
Manifold Pressure (Under Flow Conditions)	3.5" (9mb) w.c.	10" (25mb) w.c.	3.5" (9mb) w.c.	10" (25mb) w.c.

	MODEL DESIGNATIONS	
	FUEL TYPE	OPERATING SYSTEM
CB36NTR	NATURAL	MILLIVOLT
CB36NTRE	NATURAL	ELECTRONIC IGNITION
CB36PTR	PROPANE	MILLIVOLT
CB36PTRE	PROPANE	ELECTRONIC IGNITION
CX36NTR-1	NATURAL	MILLIVOLT
CX36NTRE-1	NATURAL	ELECTRONIC IGNITION
CX36PTR-1	PROPANE	MILLIVOLT
CX36PTRE-1	PROPANE	ELECTRONIC IGNITION

When the appliance is installed at elevations above 4,500 ft (1371m), and in the absence of specific recommendations from the local authority having jurisdiction, the certified high altitude input rating shall be reduced at the rate of 4% for each additional 1,000 ft (305m).

This appliance is approved for bathroom, bedroom and bed-sitting room installations and is suitable for mobile home installation.

No external electricity (110 volts or 24 volts) is required for the gas millivolt system operation. However, optional blower requires 110 volts.

Expansion / contraction noises during heating up and cooling down cycles are normal and are to be expected.

A barrier designed to reduce the risk of burns from the hot viewing glass is provided with the appliance and must be installed.

2.4 rating plate information

<p>CONFORMS TO / CONFORME AUX: ANSI Z21.50-2016, CERTIFIED TO / CERTIFIE CSA 2.2-2016 VENTED DECORATIVE GAS APPLIANCE / FOYER À GAZ DÉCORATIF VENTILÉ.</p> <p>DIRECT VENT GAS FIREPLACE, SUITABLE FOR BEDROOM, BATHROOM AND BED-SITTING ROOM INSTALLATION. SUITABLE FOR MOBILE HOME INSTALLATION IF INSTALLED IN ACCORDANCE WITH THE CURRENT STANDARD CAN/CSA Z240MH SERIES GAS EQUIPPED MOBILE HOMES, IN CANADA OR IN THE UNITED STATES THE MANUFACTURED HOME CONSTRUCTION AND SAFETY STANDARD, TITLE 24 CFR, PART 3280. WHEN THIS US STANDARD IS NOT APPLICABLE USE THE STANDARD FOR FIRE SAFETY CRITERIA FOR MANUFACTURED HOME INSTALLATIONS, SITES AND COMMUNITIES, ANSI / NFPA 501A. FOR USE WITH BARRIER W565-0144. FOLLOW THE INSTALLATION INSTRUCTIONS LOCATED IN THE INSTALLATION MANUAL.</p>		<p>FOYER À GAZ VENTILÉ DIR. CT. HOMOLOGUÉ POUR INSTALLATION DANS UNE CHAMBRE À COUCHER, UNE SALLE DE BAIN, UN STUDIO. APPROPRIÉ POUR INSTALLATION DANS UNE MAISON MOBILE SI SON INSTALLATION CONFORMÉ AUX XIG NC S DE LA NORME CAN/CSA Z240MH SÉRIE DE MAISONS MOBILES ÉQUIPÉ S AU GAZ. N VIGU UR AU CANADA OU AUX ÉTATS-UNIS DE LA NORME DE SÉCURITÉ ET DE CONSTRUCTION DE MAISONS MANUFACTURÉES, TITRE 24 CFR, SECTION 3280. DANS LE CAS OÙ C TTE NORME DÉTATS-UNIS NE P UT ÊTRE APPLIQUÉE, SE RÉFÉRER À LA NORME RE ACTIVE AU CRITÈRE DE M SUR S DE SÉCURITÉ CONTRE L'INCENDIE POUR LES INSTA TIONS DANS S MAISONS MANUFACTURES. L S SITES ET LES COMMUNAUTES, ANS/NFPA 501A. POUR UNE UTILISER AVEC BARRIÈRE W565-0144. SUIVEZ LES INSTRUCTIONS D'INSTALLATION SE TROUVENT DANS LE MANUEL D'INSTALLATION</p>																					
<p>9700539 (WSL) <input type="checkbox"/></p> <p>4001658 (NAC) <input type="checkbox"/></p>		<p>4001657 (NGZ) <input type="checkbox"/></p> <p>4001659 (WUSA) <input type="checkbox"/></p>																					
<p><input type="checkbox"/> B36NTR <input type="checkbox"/> CB36NTR MODEL</p> <p><input type="checkbox"/> B36NTR <input type="checkbox"/> CB36NTR</p>		<p><input type="checkbox"/> CB36 TR <input type="checkbox"/> B36PTR</p> <p><input type="checkbox"/> CB36 TRE <input type="checkbox"/> B36PTRE</p>																					
<p>0-4500FT (0-1370m) ALTITUDE / ELEVATION</p> <p>18,000 BTU/h IN UT / ALI ENTATION</p>		<p>0-4500FT (0-1370m) ALTITUDE / ELEVATION</p> <p>18,000 BTU/h IN UT / ALI ENTATION</p>																					
<p>13,000 BTU/h REDUCED IN UT / ALI ENTATION REDUITE</p> <p>MANIFOLD PRESSURE: 3.5" (9 B) WATER COLU N</p> <p>PRESSION AU COLLECTEUR: 3.5" (9 B) D'UNE COLONNE D'EAU</p>		<p>13,500 BTU/h REDUCED IN UT / ALI ENTATION REDUITE</p> <p>ANIFO D RESSURE: 10" (25MB) WATER COLUMN</p> <p>RESSION AU COLLECTEUR: 10" (25MB) D'UNE COLONNE D'EAU</p>																					
<p>MINIMUM SUPPLY PRESSURE: 4.5" (11 B) WATER COLU N</p> <p>PRESSION D' LIMENT TION MINIM LE: 4.5" (11 B) D'UNE COLONNE D'EAU</p>		<p>MINIMUM SUPPLY PRESSURE: 11" (27MB) WATER COLUMN</p> <p>RESSION D'ALIMENTATION MINIMALE: 11" (27MB) D'UNE COLONNE D'EAU</p>																					
<p>MAXIMUM SUPPLY PRESSURE: 7.0" (17 B) WATER COLU N</p> <p>PRESSION D' LIMENT TION M XIM LE: 7.0" (17 B) D'UNE COLONNE D'EAU</p>		<p>MAXIMUM SUPPLY PRESSURE: 13" (32MB) WATER COLUMN</p> <p>RESSION D'ALIMENTATION MAXIMALE: 13" (32MB) D'UNE COLONNE D'EAU</p>																					
<p>NOT FOR USE WITH SOLID FUEL. FOR USE WITH GL SS DOORS CERTIFIED WITH THIS UNIT ONLY.</p> <p>WARNING: THIS FIREPLACE U ES ND REQUIRES F ST CTING THER COUPLE. REPLACE ONLY WITH A FA T ACTING THERMOCOUPLE. UPPLIED BY WOLF STEEL LTD. DO NOT ADD ANY MATERIAL TO THE PPLI NCE, WHICH WILL COME IN CONT CT WITH THE FLAMES, OTHER THAN THAT UPPLIED BY THE NUF CTURER WITH THE PPLI NCE. MINIMUM CLEARANCE TO COMBUSTIBLE MATERIALS /</p>		<p>UN COMBUSTIBLE SOLIDE NE DOIT PAS ÊTRE UTILISÉ AVEC CET APPAREIL. UTILISER AVEC LES PORTES VITRÉES HOMOLOGUÉES SEULEMENT AVEC CETTE UNITÉ.</p> <p>AVERTISSEMENT: CE FOYER UTILISÉ ET REQUIÈRT UN THERMOCOUPLE À ACTION RAPIDE. REMPLACEZ UNIQUEMENT AVEC UN THERMOCOUPLE À ACTION RAPIDE DE WOLF STEEL L TÉE. N'AJOUTEZ PAS A CET APPAREIL AUCUN MATÉRIAU DEVANT ENTRER EN CONTACT AVEC LES FLAMMES AUTRE QUE CELUI QUI EST FOURNI AVEC CET APPAREIL PAR LE FABRICANT. THE APPLIANCE MUST BE VENTED USING THE APPROPRIATE WOLF STEEL VENT KITS. SEE OWNERS INSTALLATION MANUAL FOR VENTING SPECIFICS. PROPER REINSTALLATION AND RESEALING IS NECESSARY AFTER SERVICING THE VENT-AIR INTAKE SYSTEM. L'APPAREIL DOIT ÉVACUER SES GAZ EN UTILISANT L'ENSEMBLE D'ÉVACUATION PROPRE À NAPOLÉON. RÉFÉRER AU MANUEL D'INSTALLATION DE PROPRIÉTAIRE POUR L'ÉVACUATION PRÉCISE. IL EST IMPORTANT DE BIEN REINSTALLER ET RECELLER L'ÉVENT APRÈS AVOIR ASSURÉ LE MAINTIEN DU</p>																					
<p>DEGAGEMENTS MINIMAUX DES MATÉRI UX COMBU TIBLES:</p> <table border="1"> <tr> <td>TOP / DESSUS</td> <td>0</td> <td>RECE ED DEPTH / PROFONDEUR D'ENC STRE</td> <td>16"</td> </tr> <tr> <td>FLOOR / PLANCHER</td> <td>0</td> <td>VENT IDES / COTES DE L'EVENT</td> <td>1"</td> </tr> <tr> <td>SIDES / COTES</td> <td>0</td> <td>VENT TOP / EVENT UPERIEUR</td> <td>3"</td> </tr> <tr> <td>BACK / ARRIERE</td> <td>0</td> <td>VENT BOTTOM / EVENT INFERIEUR</td> <td>1"</td> </tr> <tr> <td>MANTEL / MANTEAU</td> <td>2"</td> <td></td> <td></td> </tr> </table> <p>* MAXIMUM HORIZONTAL EXTENSION / L'EXTENSION HORIZONTALE MAXIMALE: 2". SEE INSTRUCTION MANUAL FOR GREATER SAMPLE EXTENSIONS. REFERER AU MANUEL D'INSTRUCTION POUR DES EXTENSIONS PLUS GRANDES.</p> <p>SEE OWNER'S INSTRUCTION MANUAL FOR MINIMUM AND MAXIMUM VENT LENGTHS. REFERER AU MANUEL D'INSTALLATION DE PROPRIÉTAIRE POUR LES LONGUEURS D'ÉVACUATION MINIMALE ET MAXIMALE.</p> <p>WOLF STEEL LTD.</p> <p>24 NAPOLEON ROAD, BARRIE, ON, L4M 0G8 CANADA</p>		TOP / DESSUS	0	RECE ED DEPTH / PROFONDEUR D'ENC STRE	16"	FLOOR / PLANCHER	0	VENT IDES / COTES DE L'EVENT	1"	SIDES / COTES	0	VENT TOP / EVENT UPERIEUR	3"	BACK / ARRIERE	0	VENT BOTTOM / EVENT INFERIEUR	1"	MANTEL / MANTEAU	2"			<p>SYSTEME DE PRISE D'AIR: DECORATIVE PRODUCT: NOT FOR USE AS A HEATING APPLIANCE</p> <p>PRODUIT DÉCORATIF: NE PAS UTILISER COMME APPAREIL DE CHAUFFAGE.</p> <p>ELECTRICAL RATING / CLASSIFICATION: 115V 0.82AMP, 60HZ</p> <p>OPTIONAL FAN KIT / ENSEMBLE DE VENTILATEUR FACULTATIF: EP35</p> <p>SERIAL NUMBER/NO. DE SERIE: B36</p> <p>W385-1987 / A</p>	
TOP / DESSUS	0	RECE ED DEPTH / PROFONDEUR D'ENC STRE	16"																				
FLOOR / PLANCHER	0	VENT IDES / COTES DE L'EVENT	1"																				
SIDES / COTES	0	VENT TOP / EVENT UPERIEUR	3"																				
BACK / ARRIERE	0	VENT BOTTOM / EVENT INFERIEUR	1"																				
MANTEL / MANTEAU	2"																						

For rating plate location, see "installation overview" section.

This illustration is for reference only. Refer to the rating plate on the appliance for accurate information.

NOTE: The rating plate must remain with the appliance at all times. It must not be removed.

3.0 venting

! WARNING

RISK OF FIRE, MAINTAIN SPECIFIED AIR SPACE CLEARANCES TO VENT PIPE AND APPLIANCE.

THE VENT SYSTEM MUST BE SUPPORTED EVERY 3FT (0.9m) FOR BOTH VERTICAL AND HORIZONTAL RUNS. USE SUPPORTS OR EQUIVALENT NON-COMBUSTIBLE STRAPPING TO MAINTAIN THE REQUIRED CLEARANCE FROM COMBUSTIBLES. USE WOLF STEEL LTD. SUPPORT RING ASSEMBLY W010-0370 OR EQUIVALENT NON-COMBUSTIBLE STRAPPING TO MAINTAIN THE MINIMUM CLEARANCE TO COMBUSTIBLES FOR BOTH VERTICAL AND HORIZONTAL RUNS. SPACERS ARE ATTACHED TO THE INNER PIPE AT PREDETERMINED INTERVALS TO MAINTAIN AN EVEN AIR GAP TO THE OUTER PIPE. THIS GAP IS REQUIRED FOR SAFE OPERATION. A SPACER IS REQUIRED AT THE START, MIDDLE AND END OF EACH ELBOW TO ENSURE THIS GAP IS MAINTAINED. THESE SPACERS MUST NOT BE REMOVED.

THIS APPLIANCE USES A 4" (102mm) EXHAUST / 7" (178mm) AIR INTAKE VENT PIPE SYSTEM. Refer to the section applicable to your installation.

For safe and proper operation of the appliance follow the venting instruction exactly. Deviation from the minimum vertical vent length can create difficulty in burner start-up and/or carboning. Under extreme vent configurations, allow several minutes (5-15) for the flame to stabilize after ignition. Although not a requirement, it is recommended for vent lengths that pass through unheated spaces (attics, garages, crawl spaces) be insulated with the insulation wrapped in a protective sleeve to minimize condensation. Provide a means for visually checking the vent connection to the appliance after the appliance is installed. Use a fire restop, vent pipe shield or attic insulation shield when penetrating interior walls, floor or ceiling. The vent terminal may be painted with a high temperature paint to match exterior colours. Use an outdoor paint suitable for 400°F (204°C). Application and performance of paint is the consumer's responsibility. Spot testing is recommended.

NOTE: If for any reason the vent air intake system is disassembled; reinstall per the instructions provided for the initial installation.

NOTE: This appliance must be installed with a continuous connection of exhaust and air intake vent pipes. Utilizing alternate constructions such as a chimney as part of the vent system is not permitted.

3.1 venting lengths and components

Use only Wolf Steel, Simpson Dura-Vent, Selkirk Direct Temp, American Metal Amerivent or Metal-Fab venting components. Minimum and maximum vent lengths, for both horizontal and vertical installations, clearances from vent pipes to combustibles and air terminal locations as set out in this manual apply to all vent systems and must be adhered to. For Simpson Dura-Vent, Selkirk Direct Temp, American Metal Amerivent and Metal-Fab follow the installation procedure provided with the venting components.

A starter adaptor must be used with the following vent systems and may be purchased from the corresponding supplier:

VENT MANUFACTURER	STARTER ADAPTER PART NUMBER	SUPPLIER	WEBSITE
Duravent	W175-0053	Wolf Steel	www.duravent.com
Amerivent	4DSC-N2	American Metal	www.americanmetalproducts.com
Direct Temp	4DT-AAN	Selkirk	www.selkirkcorp.com
SuperSeal	4DNA	Metal-Fab	www.mtlfab.com

For Simpson Dura-Vent, Selkirk Direct Temp, American Metal Amerivent and Metal-Fab follow the installation procedure found on the website for your venting supplier.

For vent systems that provide seals on the inner exhaust flue, only the outer air intake joints must be sealed using a red high temperature silicone (RTV). This same sealant may be used on both the inner exhaust and outer intake vent pipe joints of all other approved vent systems except for the exhaust vent pipe connection to the appliance flue collar which must be sealed using the black high temperature sealant Mill Pac. High temperature sealant must be ordered separately.

When using Wolf Steel venting components, use only approved Wolf Steel rigid / flexible components with the following termination kits: wall terminal kit **GD-222**, **GD-222R**, or 1/12 to 7/12 pitch roof terminal kit **GD-110**, 8/12 to 12/12 roof terminal kit **GD-111**, flat roof terminal kit **GD-112** or periscope kit **GD-201** (for wall penetration below grade). With flexible venting, in conjunction with the various terminations, use either the 5 foot (1.5m) vent kit **GD-220** or the 10 foot (3.1m) vent kit **GD-330**.

For optimum flame appearance and appliance performance, keep the vent length and number of elbows to a minimum. The air terminal must remain unobstructed at all times. Examine the air terminal at least once a year to verify that it is unobstructed and undamaged.

Rigid and flexible venting systems must not be combined. Different venting manufacturer components must not be combined.

These vent kits allow for either horizontal or vertical venting of the appliance. The maximum allowable horizontal run is 20 feet (6.1m). The maximum allowable vertical vent length is 40 feet (12.2m). The maximum number of vent connections is two horizontally or three vertically (excluding the appliance and the air terminal connections) when using flexible venting.

For optimum performance, it is recommended that all horizontal runs have a 1" (25mm) rise per foot.

CX36-1 REQUIRED RISE ON HORIZONTAL VENTING			CB36 REQUIRED RISE ON HORIZONTAL VENTING		
Rear Vent	Rigid Venting	1" (25mm) / FT**	Rear Vent	Rigid Venting	0" / FT
	Flexible Venting	1" (25mm) / FT**		Flexible Venting	0" / FT
Top Vent	Rigid Venting	0" / FT	Top Vent	Rigid Venting	0" / FT
	Flexible Venting	0" / FT		Flexible Venting	0" / FT
Rear Vent Corner	Rigid Venting	6" (152mm)	Rear Vent Corner	Rigid Venting	0"
	Flexible Venting	6" (152mm)		Flexible Venting	6" (152mm)

** When a vertical rise is used as part of the venting configuration, a 0" (0mm) rise per foot is acceptable.

3.2 typical vent installation

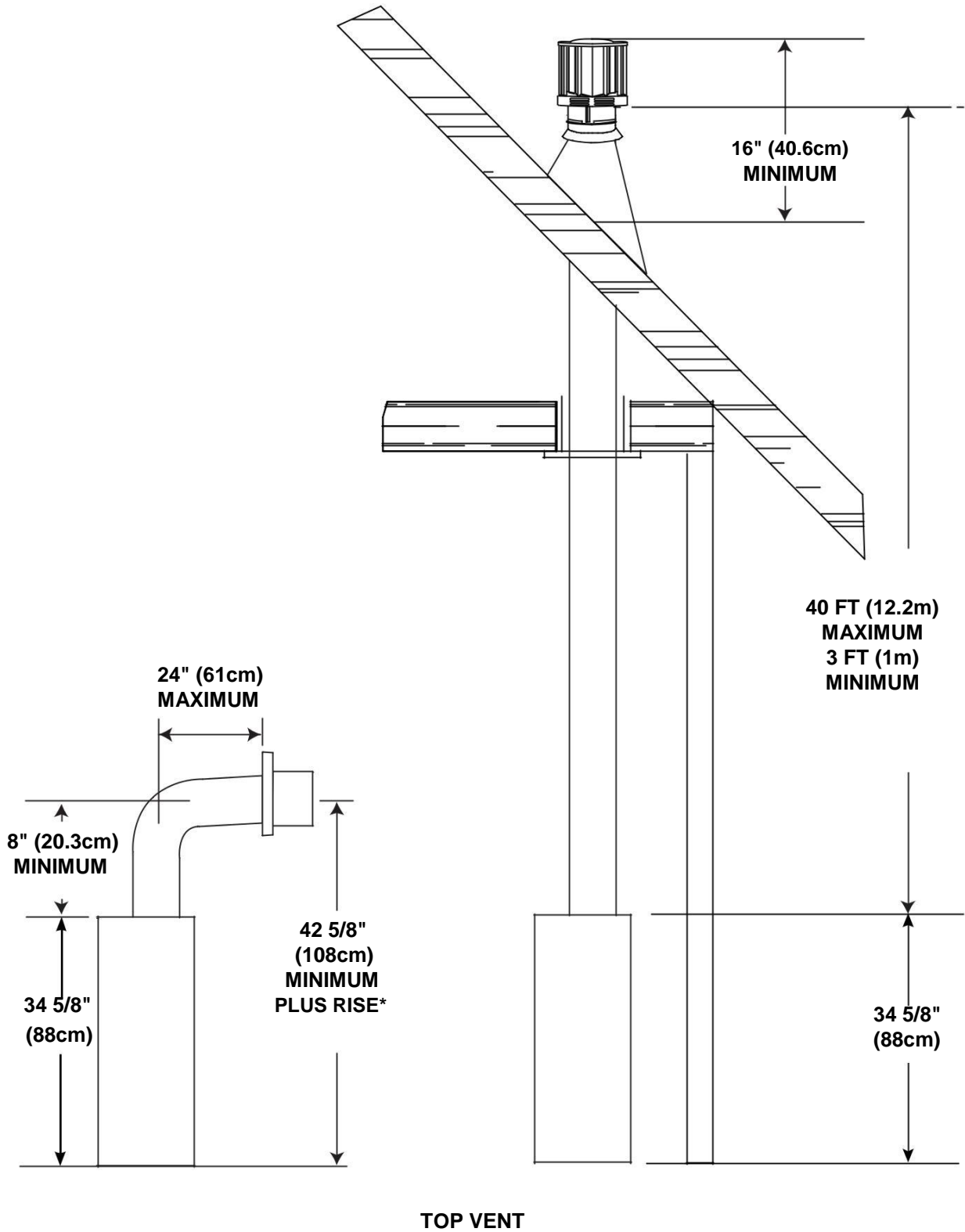

TOP VENT

* Refer to "venting" section.

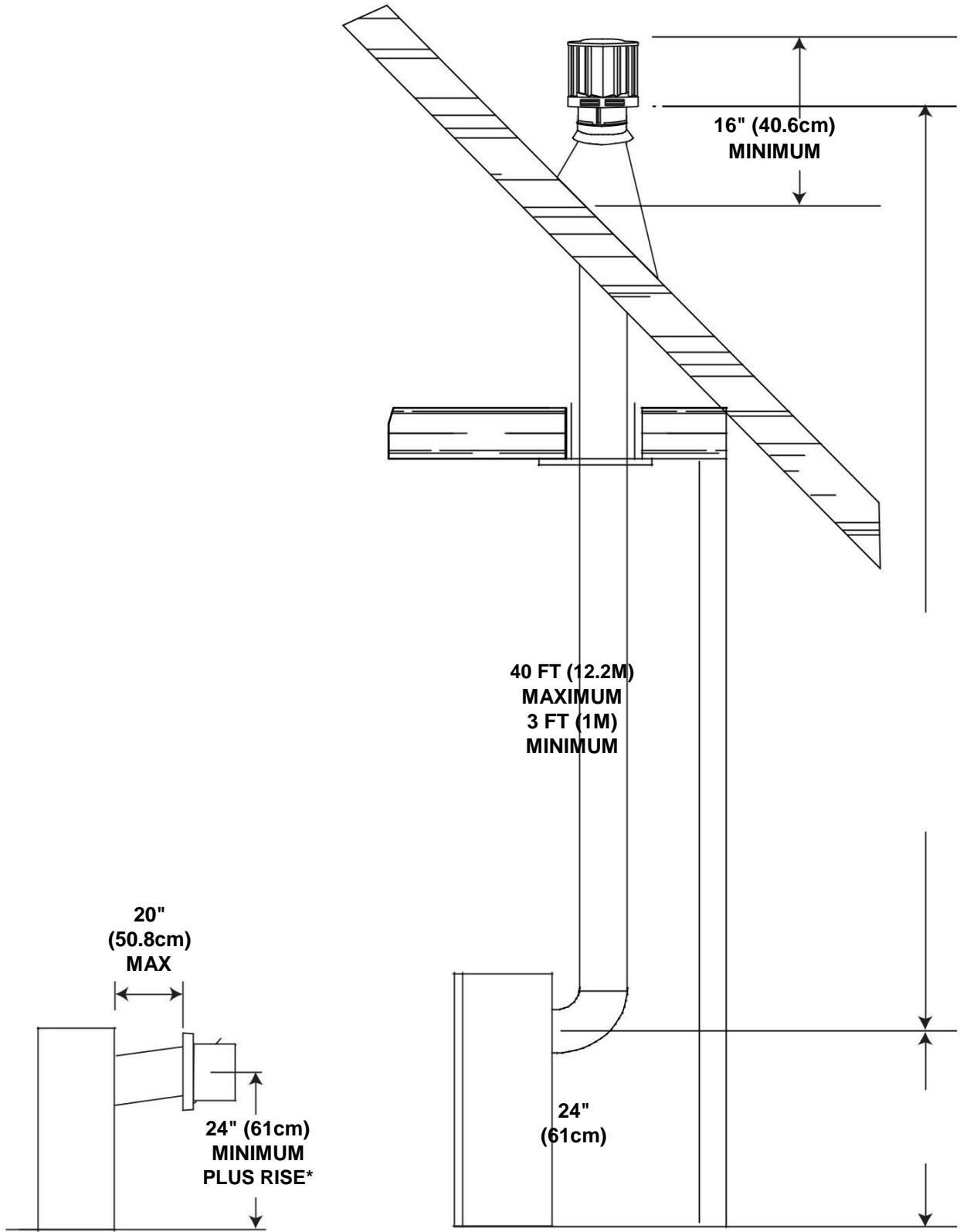

REAR VENT

* Refer to "venting" section.

3.3 special vent installations

3.3.1 periscope termination

Use the periscope kit to locate the air termination above grade. The periscope must be installed so that when final grading is completed, the bottom air slot is located a minimum 12" (30.5cm) above grade. The maximum allowable vent length is 10' (3.1m).

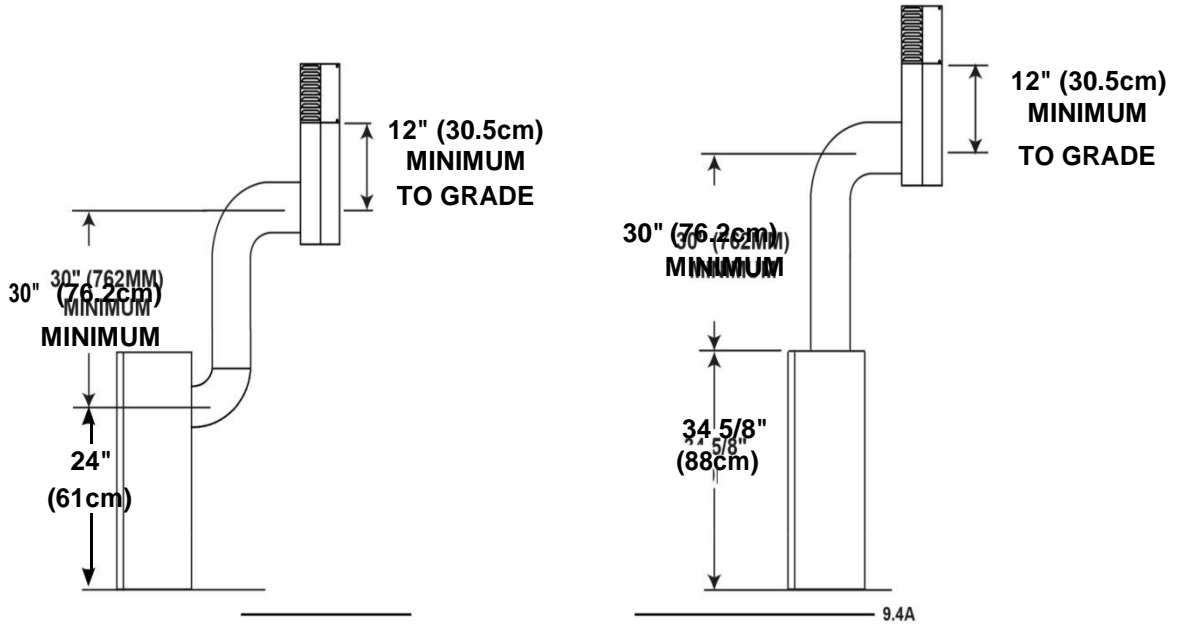

3.3.2 corner termination

The maximum vent length for a corner installation is 20" (50.8cm) of horizontal run, in addition to the 45° offset. In this case, zero rise is acceptable when using rigid venting for **CB36 models**; 6" (152mm) rise is required when using rigid venting for **CX36-1 models**. It is required to maintain a 6" (152.4mm) rise when using flexible venting for **both CB36 and CX36-1 models** (see charts and illustrations below).

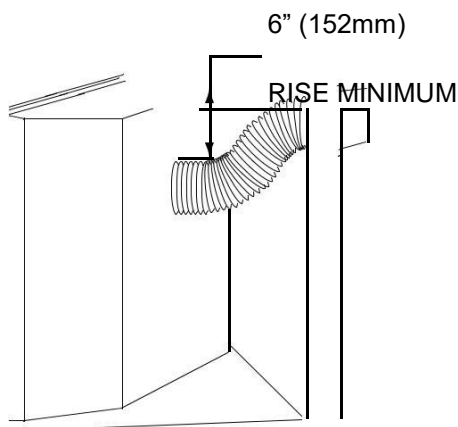

FLEXIBLE VENTING

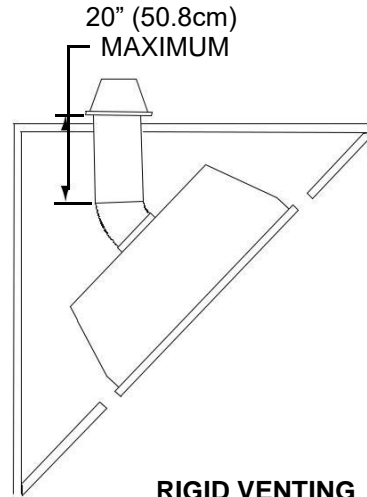

RIGID VENTING

CB36 Required Rise		
Rear Vent	Rigid Venting	0"
	Flexible Venting	6" (152mm)
Corner		

CX36-1 Required Rise		
Rear Vent	Rigid Venting	6" (152mm)
	Flexible Venting	6" (152mm)
Corner		

3.4 minimum air terminal location clearances

EN

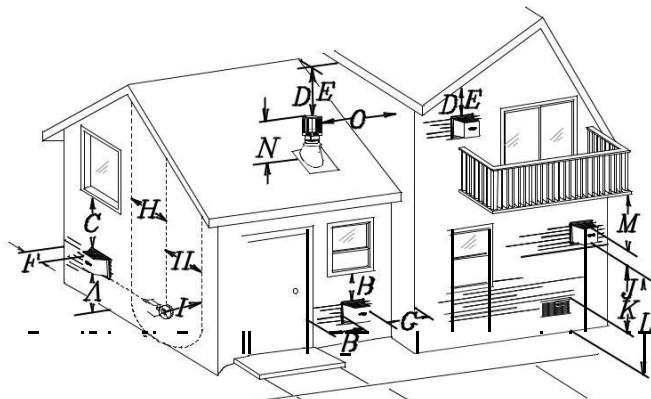

COVERED BALCONY APPLICATIONS ††*

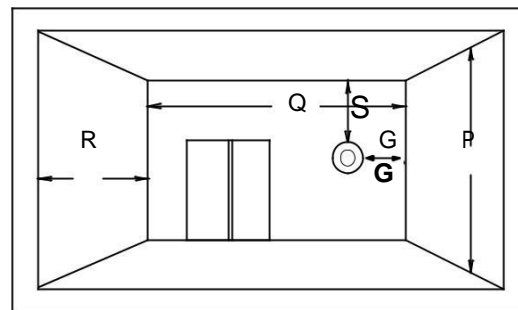

$Q_{MIN} = 3 \text{ feet}$ (0.9m)	$MAX = 2 \times Q_{ACTUAL}$	$R_{MAX} \leq 15 \text{ feet}$ (4.6m)
--------------------------------------	-----------------------------	--

NOTE: Wall terminals are for illustration purposes only. Size and shapes may vary.

	INSTALLATIONS		
	CANADA	U.S.A.	
A	12" (30.5cm)	12" (30.5cm)	Clearance above grade, veranda porch, deck or balcony.
B	12" (30.5cm)	9" (229mm)	Clearance to windows or doors that open.
C	12" (30.5cm)*	12" (30.5cm) *	Clearance to permanently closed windows.
D	18" (45.7cm)*	18" (45.7cm)**	Vertical clearance to ventilated soffit s located above the terminal within a horizontal distance of 2' (0.6m) from the center line of the terminal.
E	12" (30.5cm)**	12" (30.5cm)**	Clearance to unventilated soffit t.
F	0" (0mm)	0" (0mm)	Clearance to an outside corner wall.
G	0" (0mm)***	0" (0mm)***	Clearance to an inside non -combustible corner wall or protruding non -combustible obstructions (chimney, etc.).
	2" (51mm)***	2" (51mm)***	Clearance to an inside combustible corner wall or protruding combustible obstructions (vent chase, etc.).
H	3'(0.9m)	3'(0.9m)****	Clearance to each side of the center line extended above the meter / regulator assembly to a maximum vertical distance of 15' (4.6m).
I	3' (0.9m)	3' (0.9m)****	Clearance to a service regulator vent outlet.
J	12" (30.5cm)	9" (229mm)	Clearance to a non-mechanical air supply inlet to the building or a combustion air inlet to any other appliance.
K	6' (1.8m)	3' (0.9m) †	Clearance to a mechanical air supply inlet.
L	7' (2.1m) ‡	7' (2.1m) ****	Clearance above a paved sidewalk or paved driveway located on public property.
M	12" (30.5cm)††	12" (30.5cm)****	Clearance under a veranda, porch or deck.
N	16" (40.6cm)	16" (40.6cm)	Clearance above the roof.
O	2' (0.6m)†*	2' (0.6m) †*	Clearance from an adjacent wall including neighbouring buildings.
P	8' (2.4m)	8' (2.4m)	Roof must be non -combustible without openings.
Q	3' (0.9m)	3' (0.9m)	See chart for wider wall dimensions.
R	6' (1.8m)	6' (1.8m)	See chart for deeper wall dimensions. The terminal shall not be installed on any wall that has an opening between the terminal and the open side of the structure.
S	12" (30.5cm)	12" (30.5cm)	Clearance under a covered balcony

The terminal shall not be located less than 6 feet under a window that opens on a horizontal plane in a structure with three walls and a roof.

*Recommended to prevent condensation on windows and thermal breakage

**It is recommended to use a heat shield and to maximize the distance to vinyl clad soffit s.

***The periscope requires a minimum 18 inches clearance from an inside corner.

****This is a recommended distance. For additional requirements check local codes.

†3 feet above if within 10 feet horizontally.

‡ A vent shall not terminate where it may cause hazardous frost or ice accumulations on adjacent property surfaces. ††

Permitted only if the veranda, porch, or deck is fully open on a minimum of two sides beneath the floor.

†* Recommended to prevent recirculation of exhaust products. For additional requirements check local codes.

†† Permitted only if the balcony is fully open on a minimum of one side.

NOTE: Clearances are to be in accordance with local installation codes and the requirements of the gas supplier. In their absence, clearances are to be as listed above and are based on national codes.

3.5 venting application flow chart

EN

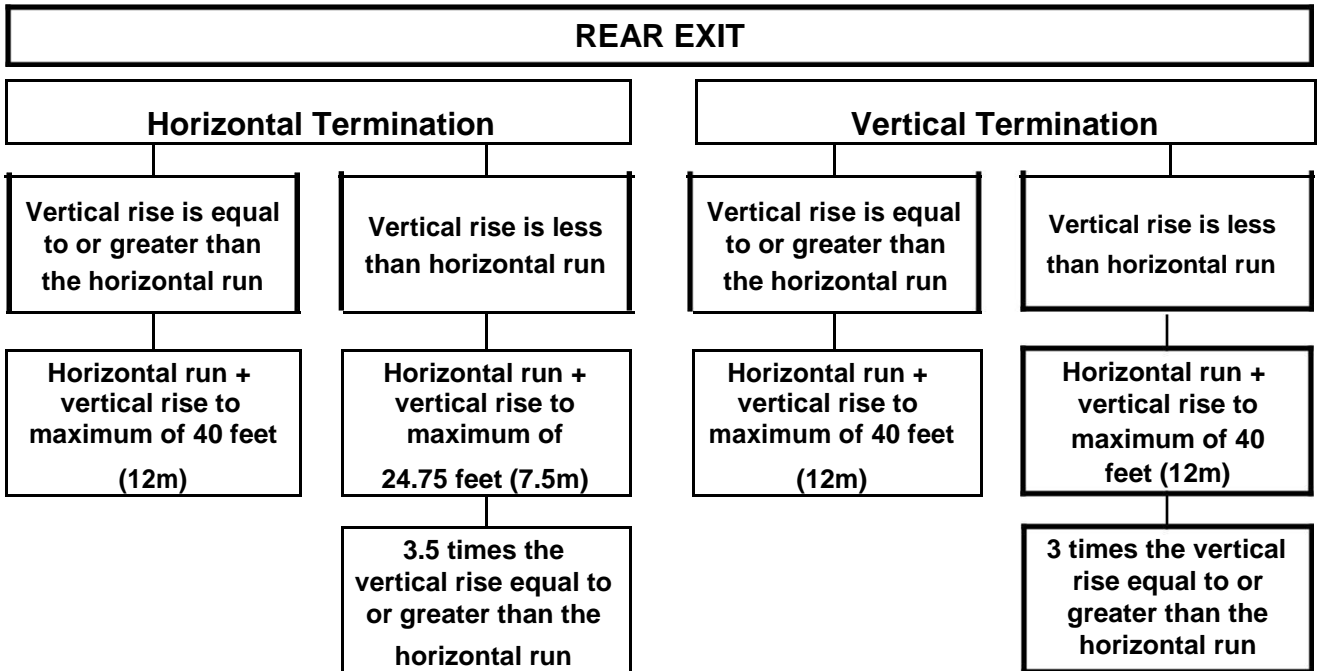
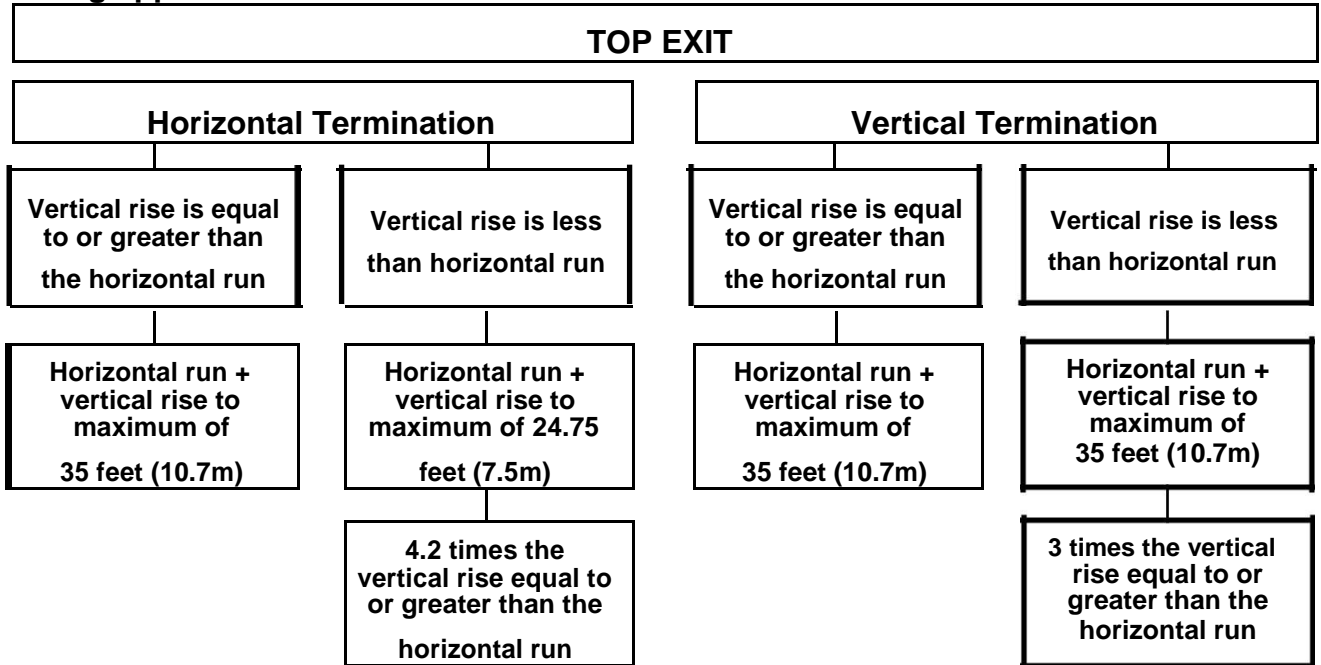

3.6 definitions

For the following symbols used in the venting calculations and examples are:

> - greater than

≥ - equal to or greater than

< - less than

≤ - equal to or less than

H_T - total of both horizontal vent lengths (H_r) and offsets (H_o) in feet

H_R - combined horizontal vent lengths in feet

H_O - offset factor: .03 (total degrees of offset - 90°*) in feet

V_T - combined vertical vent lengths in feet

14.1

3.7 elbow vent length values

	<u>FEET</u>	<u>INCHES</u>	<u>MILLIMETERS</u>
1°	0.03	0.5	12.7
15°	0.45	6.0	152.4
30°	0.9	11.0	279.4
45°	1.35	16.0	406.4
90°*	2.7	32.0	812.8

* The first 90° offset has a zero value and is shown in the formula as - 90°

3.8 top exit horizontal termination

$$(H_T) \leq (V_T)$$

Simple venting configuration (only one 90° elbow)

See graph to determine the required vertical rise V_T for the required horizontal run H_T .

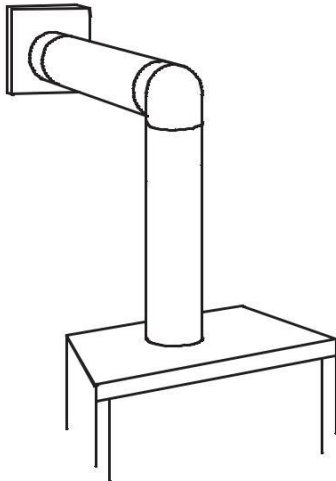

REQUIRED VERTICAL RISE IN FEET (METERS) V_T

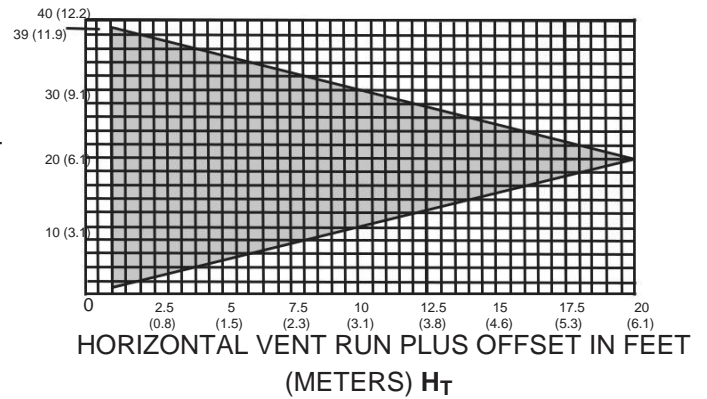

The shaded area within the lines represents acceptable values for H_T and V_T

For vent configurations requiring more than one 90° elbow, the following formulas apply:

Formula 1: $H_T \leq V_T$

Formula 2: $H_T + V_T \leq 40 \text{ feet (12.2m)}$

Example:

$V_1 = 3 \text{ FT (0.9m)}$

$V_2 = 8 \text{ FT (2.4m)}$

$V_T = V_1 + V_2 = 3 \text{ FT (0.9m)} + 8 \text{ FT (2.4m)} = 11 \text{ FT (3.4m)}$

$H_1 = 2.5 \text{ FT (0.8m)}$

$H_2 = 2 \text{ FT (0.6m)}$

$H_R = H_1 + H_2 = 2.5 \text{ FT (0.8m)} + 2 \text{ FT (0.6m)} = 4.5 \text{ FT (1.4m)}$

$H_O = .03 \text{ (three } 90^\circ \text{ elbows - } 90^\circ) = .03 \text{ (} 270^\circ - 90^\circ) = 5.4 \text{ FT (1.7m)}$

$H_T = H_R + H_O = 4.5 \text{ FT (1.4m)} + 5.4 \text{ FT (1.6m)} = 9.9 \text{ FT (3m)}$

H

$H_T + V_T = 9.9 \text{ FT (3m)} + 11 \text{ FT (3.4m)} = 20.9 \text{ FT (6.4m)}$

Formula 1: $H_T \leq V_T$
 $9.9 \text{ FT (3m)} \leq 11 \text{ FT (3.4m)}$

Formula 2: $H_T + V_T \leq 40 \text{ FT (12.2m)}$
 $20.9 \text{ FT (6.4m)} \leq 40 \text{ FT (12.2m)}$

Since both formulas are met, this vent configuration is acceptable.

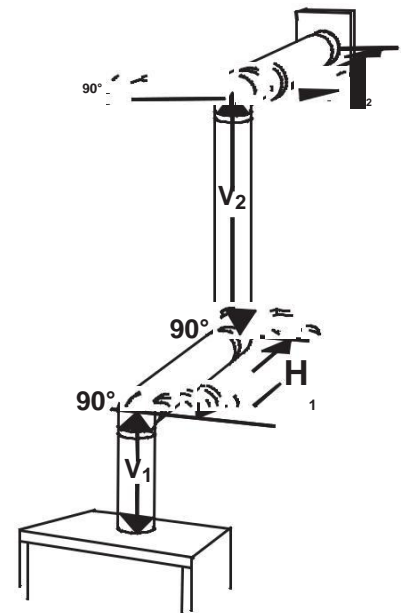

$(H_T) > (V_T)$

Simple venting configuration
(only one 90° elbow)

See graph to determine the required vertical rise V_T for the required horizontal run

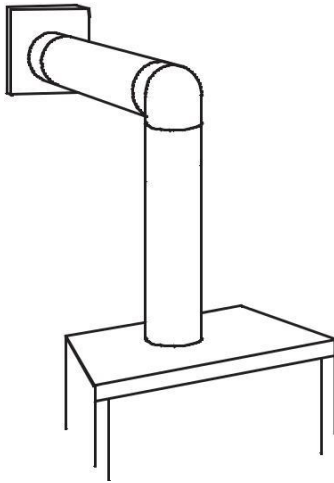

REQUIRED
VERTICAL
RISE IN INCHES
(CENTIMETERS) V_T

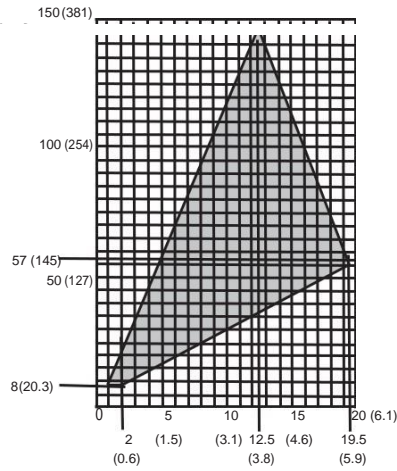

HORIZONTAL VENT RUN PLUS OF
The shaded area within the lines repr

V_T

For vent configurations requiring r

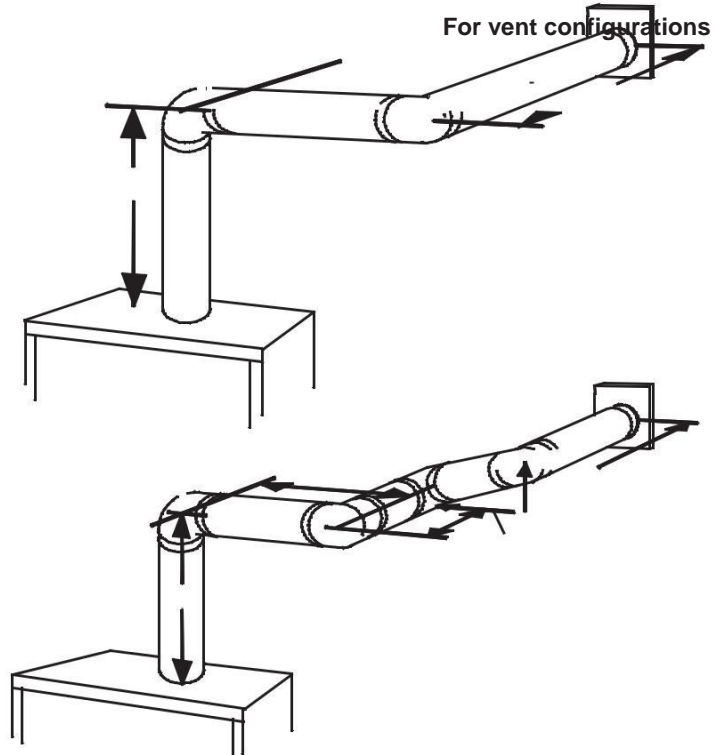

3.9 rear exit horizontal termination

$$(H_T) \leq (V_T)$$

Simple venting configuration
(only two 90° elbows)

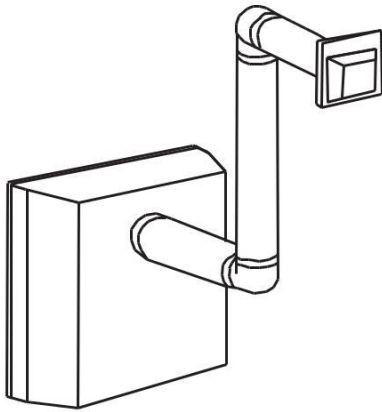

See graph to determine the required vertical rise V_T for the required horizontal run H_T .

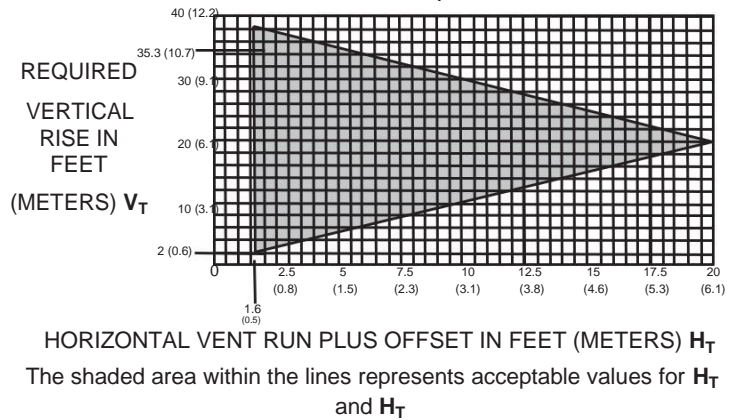

For vent configurations requiring more than two 90° elbows, the following formulas apply:

Formula 1: $H_T \leq V_T$

Formula 2: $H_T + V_T \leq 40 \text{ feet (12.2m)}$

Example:

$V_1 = 9 \text{ FT (2.7m)}$

$V_2 = 6 \text{ FT (1.8m)}$

$V_T = V_1 + V_2 = 9\text{FT (2.7m)} + 6\text{FT (1.8m)} = 15\text{FT (4.6m)}$

$H_1 = 3 \text{ FT (0.9m)}$

$H_2 = 2 \text{ FT (0.6m)}$

$H = 1.5 \text{ FT (0.5m)}$

$H_R^3 = H_1 + H_2 + H_3 = 3\text{FT (0.9m)} + 2\text{FT (0.6m)} + 1.5\text{FT (0.5m)} = 6.5\text{FT (2m)}$

$H_O = .03 \text{ (four } 90^\circ \text{ elbows} - 90^\circ) = .03 \text{ (} 360^\circ - 90^\circ) = 8.1 \text{ FT (2.5m)}$

$H_T = H_R + H_O = 6.5\text{FT (2m)} + 8.1\text{FT (2.5m)} = 14.6\text{FT (4.5m)}$

$H_T + V_T = 14.6\text{FT (4.5m)} + 15\text{FT (4.6m)} = 29.6 \text{ FT (9m)}$

Formula 1: $H_T \leq V_T$
 $14.6 \text{ FT (4.5m)} \leq 15 \text{ FT (4.6m)}$

Formula 2: $H_T + V_T \leq 40 \text{ FT (12.2m)}$
 $29.6 \text{ FT (9m)} \leq 40 \text{ FT (12.2m)}$

Since both formulas are met, this vent configuration is acceptable.

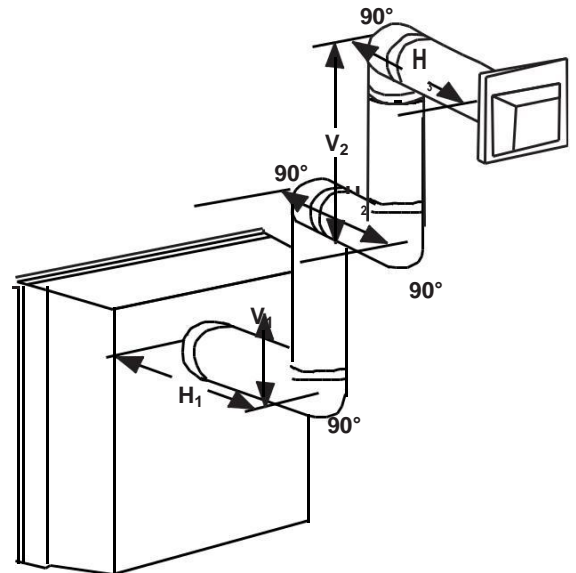

(H_T) > (V_T)

Simple venting configuration
(only two 90° elbows)

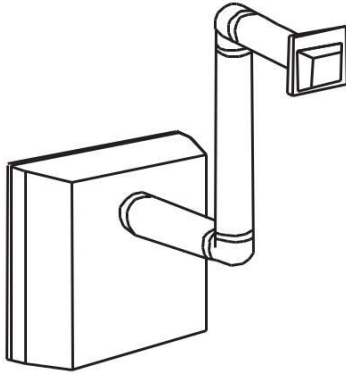

FEET
(METERS) V_T

HORIZONTAL VENT RUN PLUS OFFSET IN FEET (METERS) H_T

The shaded area within the lines represents acceptable

See graph to determine the required vertical rise V_T for the required horizontal run H_T.

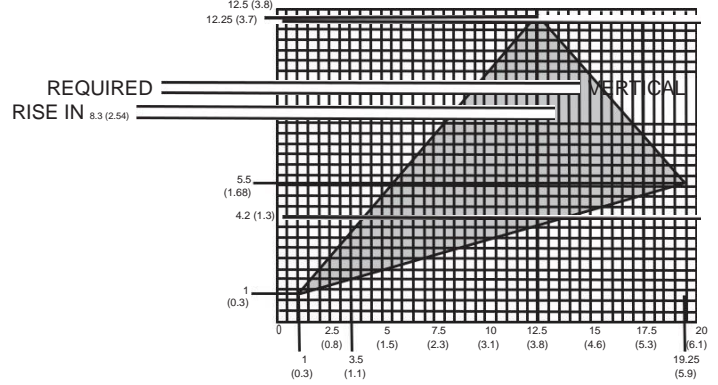

values for H_T and H_T

For vent configurations requiring more than two 90° elbows, the following formulas apply:

Formula 1: $H_T \leq 3.5V_T$

Formula 2: $H_T + V_T \leq 24.75$ feet (7.5m)

Example:

$V_1 = 4$ FT (1.2m)

$V_2 = 1.5$ FT (0.5m)

$V_T = V_1 + V_2 = 4$ FT (1.2m) + 1.5 FT (0.5m) = 5.5 FT (1.7m)

$H_1 = 2$ FT (0.6m)

$H_2 = 1$ FT (0.3m)

$H_3 = 1$ FT (0.3m)

$H_4 = 1.5$ FT (0.5m)

$H_R = H_1 + H_2 + H_3 + H_4 = 2$ FT (0.6m) + 1 FT (0.3m) + 1 FT (0.3m) + 1.5 FT (0.5m) = 5.5 FT (1.7m)

$H_o = .03$ (four 90° elbows + one 45° elbow - 90°)

$H = .03$ (90 + 90 + 90 + 90 + 45 - 90) = 9.45 FT (2.9m)

$T = H_R + H_o = 5.5$ FT (1.7m) + 9.45 FT (2.9m) = 14.95 FT (4.6m)

$H_T + V_T = 14.95$ FT (4.6m) + 5.5 FT (1.7m) = 20.45 FT (6.2m)

Formula 1: $H_T \leq 3.5V_T$

$3.5V_T = 3.5$ FT (1.1m) x 5.5 FT (1.7m) = 19.25 FT (5.9m)

14.95 FT (4.6m) < 19.25 FT (5.9m)

Formula 2: $H_T + V_T \leq 24.75$ FT (7.5m)

20.45 FT (6.2m) < 24.75 FT (7.5m)

Since both formulas are met, this vent configuration is acceptable.

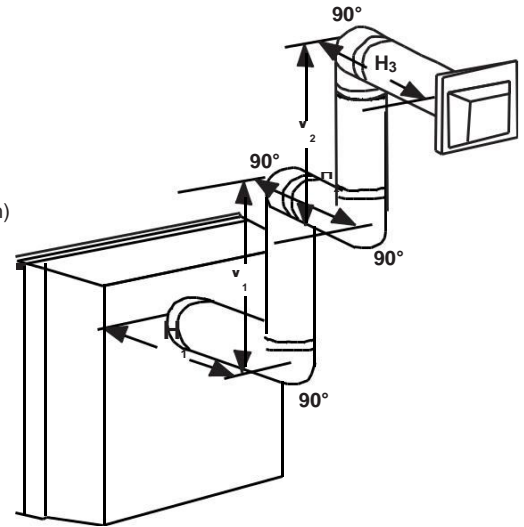

3.10 top and rear exit vertical termination

$$(H_T) \leq (V_T)$$

Simple venting configurations.

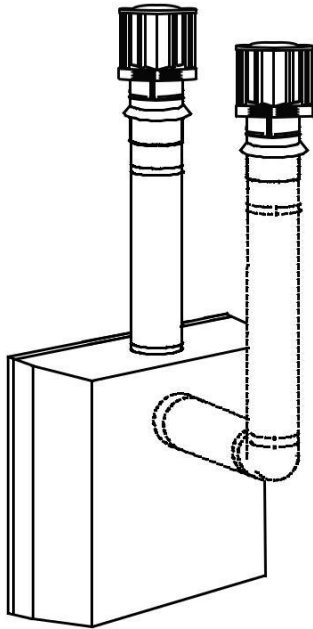

See graph to determine the required vertical rise V_T for the required horizontal run H_T .

REQUIRED VERTICAL RISE IN FEET (METERS) V_T

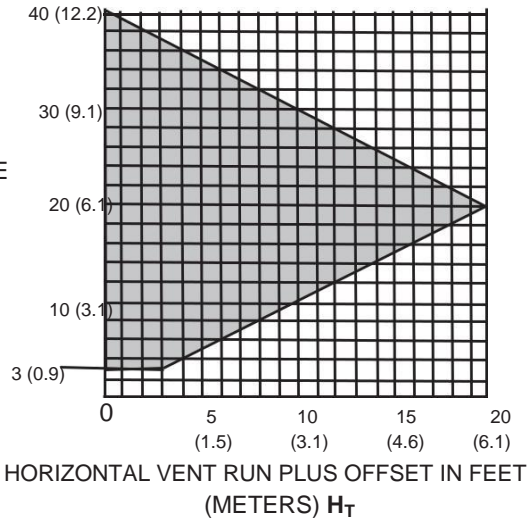

The shaded area within the lines represents acceptable values for H_T and V_T

For vent configurations requiring one or more 90° elbows (top exit) or one or more 90° elbows (rear exit), the following formulas apply:

Formula 1: $H_T \leq V_T$

Formula 2: $H_T + V_T \leq 40$ feet (12.2m)

Example:

$V_1 = 5$ FT (1.5m)

$V_2 = 6$ FT (1.8m)

$V_3 = 10$ FT (3.1m)

$V_T = V_1 + V_2 + V_3 = 5\text{FT (1.5m)} + 6\text{FT (1.8m)} + 10\text{FT (3.1m)} = 21$ FT (6.4m)

$H_1 = 8$ FT (2.4m)

$H_2 = 2.5$ FT (0.8m)

$H_R = H_1 + H_2 = 8\text{FT (2.4m)} + 2.5\text{FT (0.8m)} = 10.5\text{FT (3.2m)}$

$O = .03$ (four 90° elbows - 90°)

$= .03$ (360° - 90°) = 8.1 FT (2.5m)

$H_T = H_R + H_O = 10.5\text{FT (3.2m)} + 8.1\text{FT (2.5m)} = 18.6\text{FT (5.7m)}$

$H_T + V_T = 18.6\text{FT (5.7m)} + 21\text{FT (6.4m)} = 39.6\text{FT (12.1m)}$

Formula 1: $H_T \leq 3.5V_T$
 18.6 FT (5.7m) \leq 21 FT (6.4m)

Formula 2: $H_T + V_T \leq 40$ FT (12.2m)
 $39.6\text{FT (12.1m)} \leq 40$ FT (12.2m)

Since both formulas are met, this vent configuration is acceptable.

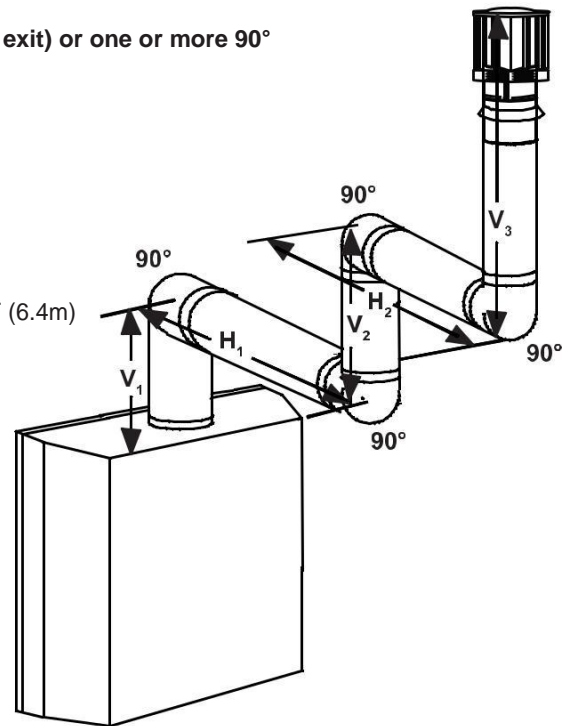

(H_T) > (V_T)

Simple venting configurations.

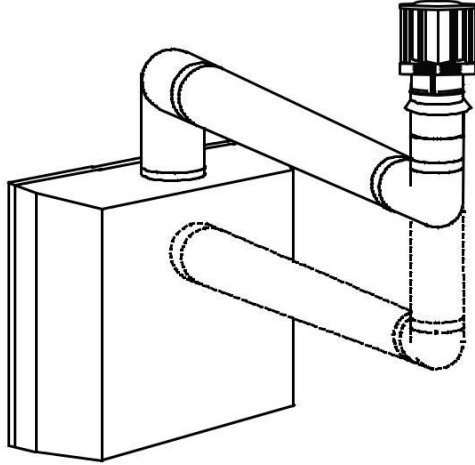

See graph to determine the required vertical rise **V_T** for the required horizontal run **H_T**.

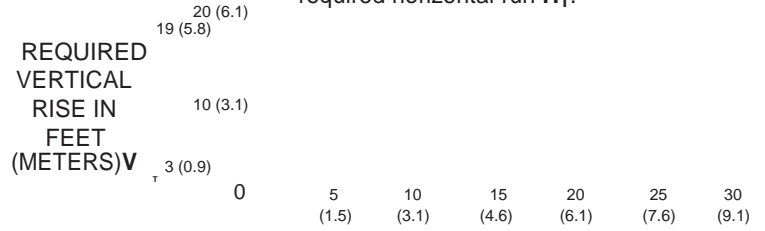

HORIZONTAL VENT RUN PLUS OFFSET IN FEET (METERS) **H_T**

The shaded area within the lines represents acceptable values for **H_T** and **H_T**

Formula 1: H
Formula 2: H
Example:
V₁ = 2 FT (0.6)
V₂ = 1 FT (0.3)
V₃ = 1.5 FT (0.45)
V_T = **V₁** + **V₂** + **V₃**
H₁ = 6 FT (1.8)
H₂ = 2 FT (0.6)
H_R = **H₁** + **H₂**
H₀ = .03 (four
H = .03 (360°
T = **H_R** + **H₀**
H_T + **V_T** = 16.
Formula 1:

3.11 rear exit

! WARNING

FAILURE TO CREATE A SEAL TO THE FIREBOX WITH THE EXHAUST COLLAR ASSEMBLY WILL CAUSE THE APPLIANCE TO FUNCTION IMPROPERLY AND CAN CAUSE INJURY OR PROPERTY DAMAGE.

EN

- A. Remove the safety barrier and glass door (see "safety barrier/door removal and installation" section).
- B. Remove the contents from the firebox and set aside. You will need the exhaust and air inlet collar.
- C. To ease assembly, remove the 4 hex head screws securing the deflector from inside the top front of the firebox (FIG 1).
- D. Place the gasket (provided with the 4" collar assembly) over the 4" (101.6mm) flue collar and bend along perforation (FIG 2).
- E. From inside the firebox, insert the 4" (101.6mm) flue collar through the back of the firebox. Install the rear exit shield onto the 4" (101.6mm) flue collar (see "rear exit shield (for rear vent only)" section).
- F. Secure the flue collar assembly, gasket, and rear exit shield using the 4 black pan head 5/8" thread cutting screws (FIG 2).

NOTE: Do not overtighten. The gasket only needs to be snug against the firebox.
- G. Re-attach the deflector using the 4 screws, and install the log set, glass door, and safety barrier.
- H. Install the 7" collar assembly, complete with gasket, onto the rear panel around the 4" (101.6mm) collar with the screws provided (FIG 3).

FIG. 1

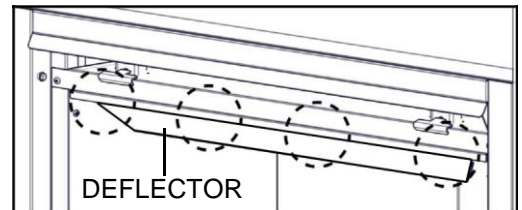
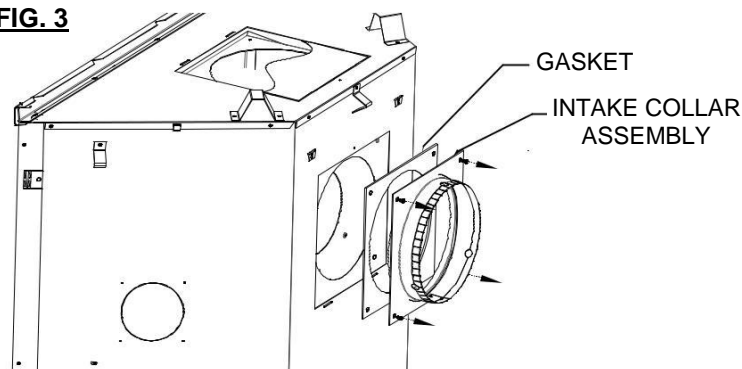

FIG. 2



FIG. 3



3.12 rear exit shield (for rear vent only)

- A. Remove the safety barrier and door from the appliance (see "safety barrier & door removal/installation" section).
- B. Loosen the 2 screws that secure the exhaust plate, and slide the shield's slotted openings behind the screwheads. Tighten the 2 previously loosened screws (FIG 1).
- C. Reinstall the door and safety barrier assembly on the appliance (see "safety barrier & door removal/installation" section).

NOTE: This shield is used to block the view through the venting to the outdoors.

FIG. 1

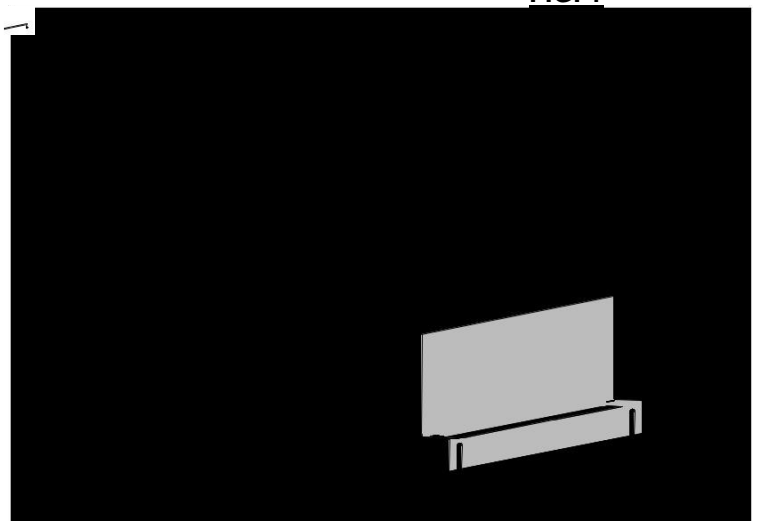

3.13 top exit

EN

!WARNING

FAILURE TO CREATE A SEAL TO THE FIREBOX WITH THE EXHAUST COLLAR ASSEMBLY WILL CAUSE THE APPLIANCE TO FUNCTION IMPROPERLY AND CAN CAUSE INJURY OR PROPERTY

DAMAGE.

NOTE: This appliance has been factory shipped as a rear vent.

- A. Remove the safety barrier and glass door (see "safety barrier & door
 - B. Remove the contents from the firebox and set aside. You will need the exhaust and air inlet collar.
 - C. To ease assembly, remove the 4 hex head screws, securing the deflector from inside the top front of the firebox (FIG 1).
 - D. Remove the 4 screws. Install the outer cover plate and gasket onto the back of the appliance using the 4 previously removed screws (FIG 2).
 - E. Remove the 1 1/2" (38.1mm) thick batt of insulation and **discard** (FIG 2).
 - F. Remove the 4 screws securing the inner cover plate, 'o' ring (CX36-1 only), and gasket. Remove the inner cover plate and discard (FIG 2).
 - G. Reinstall the 'o' ring (CX36-1 only) and gasket into the appliance using the previously removed screws (FIG 2).
 - H. Place the 7" (177.8mm) intake collar and gasket onto the top of the appliance and secure using 4 screws.
- TIP: The manual baggie supplies the gasket (CX36-1 only) and screws (packaged in another separate baggie).**
- I. From inside the firebox, install the 4" (101.6mm) exhaust collar with gasket up through the top of the firebox, and secure with the the 4 hex head 3/4" black screws supplied in the manual baggie.
- NOTE: Do not overtighten. The gasket only needs to be snug against the firebox.**
- J. Reinstall the top deflector, log set, glass door, and safety barrier.

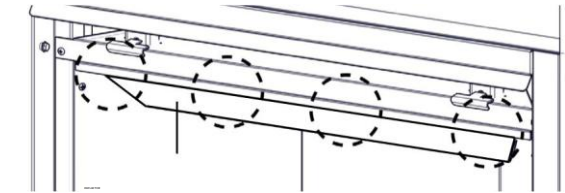
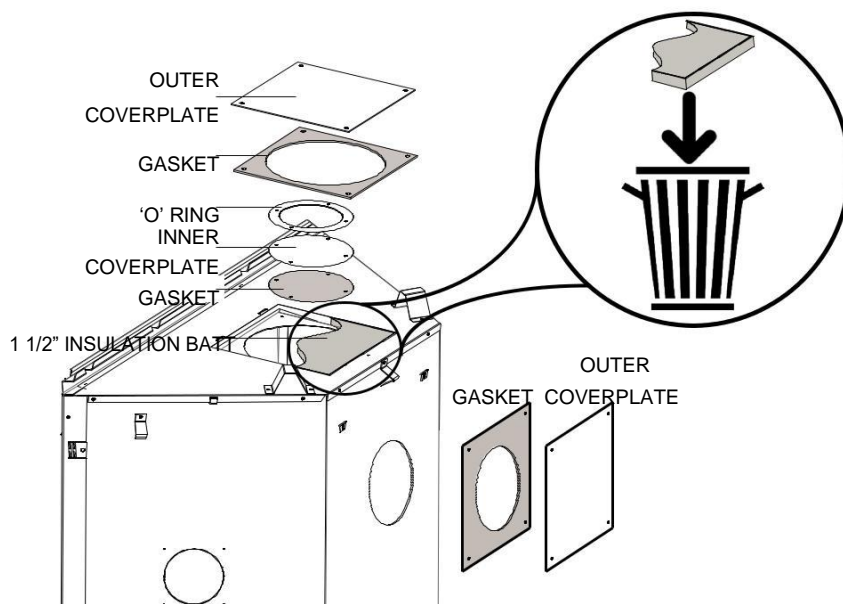
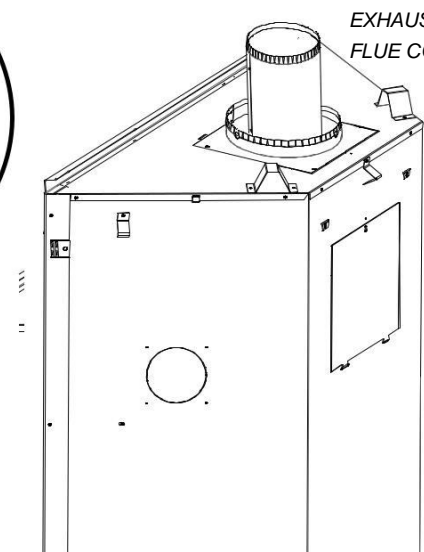

FIG. 2



EXHAUST
FLUE COLLAR

FIG. 3



4.0 installation

 WARNING	
ENSURE TO UNPACK ALL LOOSE MATERIALS FROM INSIDE THE FIREBOX PRIOR TO HOOKING UP THE GAS AND ELECTRICAL SUPPLY.	
IF YOUR APPLIANCE IS SUPPLIED WITH A REMOTE, ENSURE THE REMOTE RECEIVER IS IN THE "OFF" POSITION PRIOR TO HOOKING UP THE GAS AND ELECTRICAL SUPPLY TO THE APPLIANCE.	
FOR SAFE AND PROPER OPERATION OF THE APPLIANCE, FOLLOW THE VENTING INSTRUCTIONS EXACTLY.	
ALL EXHAUST AND INTAKE VENT PIPE JOINTS MUST BE SEALED USING RED RTV HIGH TEMP SILICONE SEALANT (W573-0002) (NOT SUPPLIED) OR BLACK HIGH TEMP MILL PAC (W573-0007) (NOT SUPPLIED) WITH THE EXCEPTION OF THE APPLIANCE EXHAUST FLUE COLLAR WHICH MUST BE SEALED USING MILL PAC.	
IF USING PIPE CLAMPS TO CONNECT VENT COMPONENTS, A MINIMUM OF 3 SCREWS MUST ALSO BE USED TO ENSURE THE CONNECTION CANNOT SLIP OFF.	
DO NOT CLAMP THE FLEXIBLE VENT PIPE.	
RISK OF FIRE, EXPLOSION OR ASPHYXIATION. IMPROPER SUPPORT OF THE ENTIRE VENTING SYSTEM MAY ALLOW VENT TO SAG AND SEPARATE. USE VENT RUN SUPPORTS AND CONNECT VENT SECTIONS PER INSTALLATION INSTRUCTIONS.	
RISK OF FIRE, DO NOT ALLOW LOOSE MATERIALS OR INSULATION TO TOUCH THE VENT PIPE. REMOVE INSULATION TO ALLOW FOR THE INSTALLATION OF THE ATTIC SHIELD AND TO MAINTAIN CLEARANCES TO COMBUSTIBLES.	

EN

4.1 wall and ceiling protection

 WARNING	
DO NOT FILL THE SPACE BETWEEN THE VENT PIPE AND ENCLOSURE WITH ANY TYPE OF MATERIAL. DO NOT PACK INSULATION OR COMBUSTIBLES BETWEEN CEILING FIRESTOPS. ALWAYS MAINTAIN SPECIFIED CLEARANCES AROUND VENTING AND FIRESTOP SYSTEMS. INSTALL WALL SHIELDS AND FIRESTOPS AS SPECIFIED. FAILURE TO KEEP INSULATION OR OTHER MATERIALS AWAY FROM VENT PIPE MAY CAUSE FIRE.	

For clearances to combustible materials from the vent pipe, see "framing" section.

4.1.1 horizontal installation

! WARNING

THE FIRESTOP ASSEMBLY MUST BE INSTALLED WITH THE VENT SHIELD TO THE TOP.

TERMINALS MUST NOT BE RECESSED INTO A WALL OR SIDING MORE THAN THE DEPTH OF THE RETURN FLANGE OF THE MOUNTING PLATE.

This application occurs when venting through an exterior wall. Having determined the correct height for the air terminal location, cut and frame a hole in the exterior wall as illustrated to accommodate the firestop assembly. Dry fit the firestop assembly before proceeding to ensure the brackets on the rear surface fit to the inside surface of the horizontal framing.

The vent shield must be installed to the full depth of the combustible wall. The length of the vent shield may be cut shorter for combustible walls that are less than 8 1/2" (216mm) thick. **NOTE: Bend the tabs for reduced side clearances or move the shield for reduced top clearances.**

- A. Apply a bead of caulking (not supplied) around the corner edge of the inside surface of the firestop assembly, fit the firestop assembly to the hole and secure using the 4 screws (supplied in your manual baggie).

NOTE: Do not fill the air space between the firestop spacer and the exterior wall with any type of insulating material (i.e., spray foam).

- B. Once the vent pipe is installed in its final position, apply red RTV silicone sealant (W573-0002) (not supplied) between the pipe and the firestop.

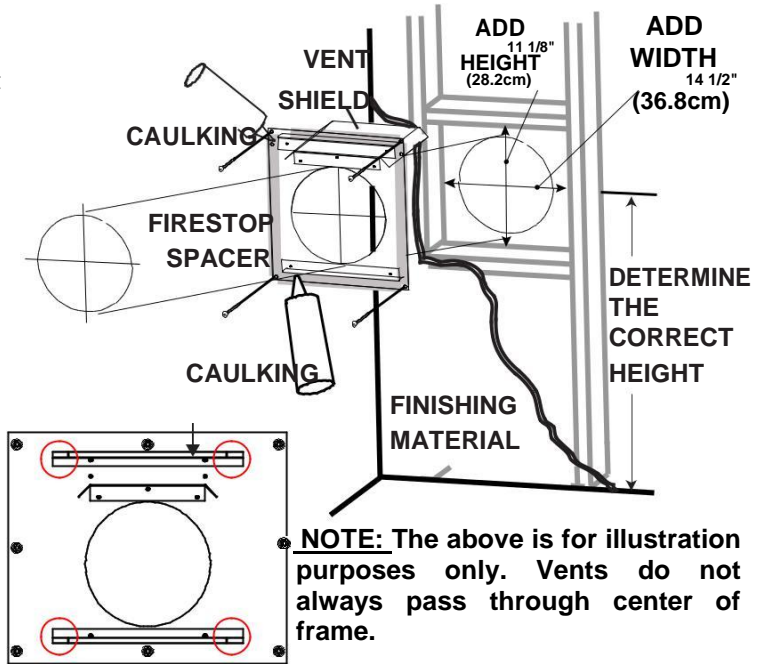

NOTE: The above is for illustration purposes only. Vents do not always pass through center of frame.

4.1.2 vertical installation

This application occurs when venting through a roof. Installation kits for various roof pitches are available from your authorized dealer / distributor. See accessories to order specific kits required.

- A. Determine the air terminal location, cut and frame a square opening as illustrated in the ceiling and the roof to provide the minimum 1" (25mm) clearance between the vent pipe and any combustible material. Try to center the vent pipe location midway between two joists to prevent having to cut them. Use a plumb bob to line up the center of the openings. A vent pipe shield will prevent any materials such as insulation, from filling up the 1" (25mm) air space around the pipe. Nail headers between the joist for extra support.
- B. Apply a bead of caulking (not supplied) to the framework or to the Wolf Steel vent pipe shield plate or equivalent (in the case of a finished ceiling), and secure over the opening in the ceiling. A firestop must be placed on the bottom of each framed opening in a roof or ceiling that the venting system passes through. Apply a bead of caulking all around and place a firestop spacer over the vent shield to restrict cold air from being drawn into the room or around the fireplace. Ensure that both spacer and shield maintain the required clearance to combustibles. Once the vent pipe is installed in its final position, apply Mill Pac sealant (W573-0007) (not supplied) or red RTV silicone (W573-0002) (not supplied) between the pipe and the firestop assembly.

Continued on next page.

- C. In the attic, slide the vent pipe collar down to cover up the open end of the shield and

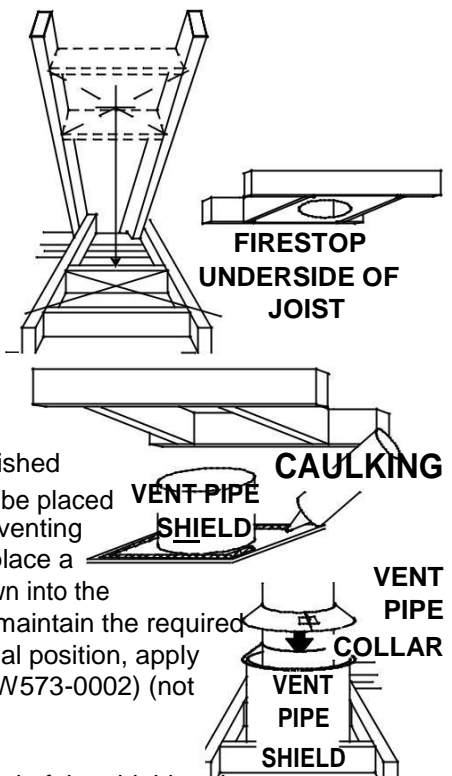

- C. In the attic, slide the vent pipe collar down to cover up the open end of the shield and tighten. This will prevent any materials, such as insulation, from filling up the 1" (2.5mm) air space around the pipe.

4.2 using flexible vent components

! WARNING

DO NOT ALLOW THE INNER FLEX PIPE TO BUNCH UP ON HORIZONTAL OR VERTICAL RUNS AND ELBOWS. KEEP IT PULLED TIGHT.

SPACERS ARE ATTACHED TO THE INNER FLEX PIPE AT PREDETERMINED INTERVALS TO MAINTAIN AN EVEN AIR GAP TO THE OUTER FLEX PIPE. THIS GAP IS REQUIRED FOR SAFE OPERATION. A SPACER IS REQUIRED AT THE START, MIDDLE AND END OF EACH ELBOW TO ENSURE THIS GAP IS MAINTAINED. THESE SPACERS MUST NOT BE REMOVED.

For safe and proper operation of the appliance, follow the venting instructions exactly.

All inner flex pipe and outer flex pipe joints may be sealed using high temperature red RTV silicone W573-0002 (not supplied) or the high temperature sealant W573-0007 Mill Pac (not supplied). However, the high temperature sealant W573-0007 Mill Pac (not supplied) must be used on the joint connecting the inner flex pipe and the exhaust flue collar.

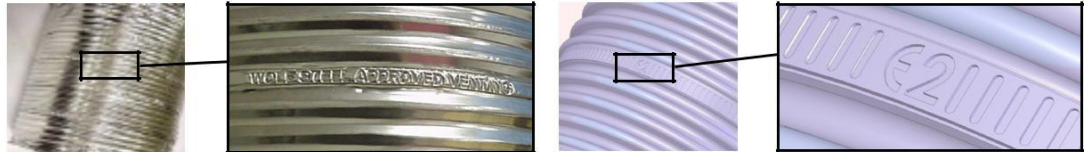
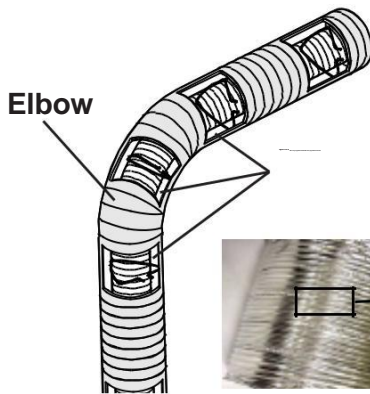

"Wolf Steel Approved Venting" or "E2" as identified by the stamp on the flex pipes.

4.2.1 horizontal air terminal installation

- A. Stretch the inner flex pipe to the required length taking into account the additional length needed for the finished wall surface. Apply a heavy bead of the Mill Pac sealant (W573-0007) (not supplied) to the inner sleeve of the air terminal. Slip the vent pipe a minimum of 2" (50.8mm) over the inner sleeve of the air terminal and secure with a minimum of 3 screws.
- B. Using the outer flex pipe, slide over the outer combustion air sleeve of the air terminal and secure with a minimum of 3 screws. Seal using red RTV silicone (W573-0002) (not supplied).
- C. Insert the vent pipes through the firestop maintaining the required clearance to combustibles. Holding the air terminal (lettering in an upright, readable position), secure to the exterior wall and make weather tight by sealing with caulking (not supplied).
- D. If more vent pipe needs to be used to reach the fireplace, couple them together as illustrated. The vent system must be supported approximately every 3 feet (0.9m) for both vertical and horizontal runs. Use non-combustible strapping to maintain the minimum clearance to combustibles.

ADD FASTENER TYPE

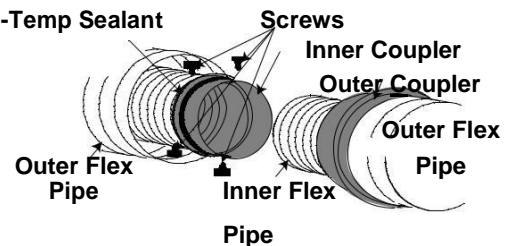
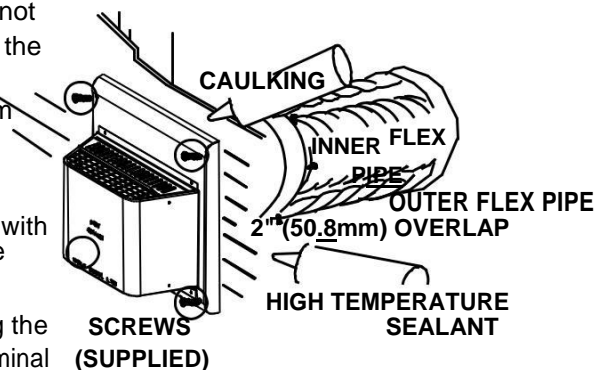

The air terminal mounting plate may be recessed into the exterior wall or siding no greater than the depth of its return flange.

4.2.2 vertical air terminal installation

EN

! WARNING**MAINTAIN A MINIMUM 2" (51mm) SPACE BETWEEN THE AIR INLET BASE AND THE STORM COLLAR.****NOTE : Fastening hardware provided with appropriate roof terminal and liner kits.**

- A.** Fasten the roof support to the roof using 6 screws. The roof support is optional. In this case the venting is to be adequately supported using either an alternate method suitable to the authority having jurisdiction or the optional roof support.
- B.** Stretch the inner flex pipe to the required length. Slip the inner flex pipe a minimum of 2" (51mm) over the inner pipe of the air terminal connector and secure with a minimum of 3 screws. Seal using a heavy bead of Mill Pac sealant (W573-0007) (not supplied).
- C.** Repeat using the outer flex pipe, using a heavy bead of red RTV silicone (W573-0002) (not supplied) and a minimum of 3 screws.
- D.** Thread the air terminal connector / vent pipe assembly down through the roof. The air terminal must be positioned vertically and plumb. Attach the air terminal connector to the roof support, ensuring that the top of the air terminal is 16" (40.6cm) above the highest point that it penetrates the roof.
- E.** Remove nails from the shingles, above and to the sides of the air terminal connector. Place the flashing over the air terminal connector leaving a min. 3/4" (19mm) of the air terminal connector showing above the top of the flashing. Slide the flashing underneath the sides and upper edge of the shingles. Ensure that the air terminal connector is properly centered within the flashing, giving a 3/4" (19mm) margin all around. Fasten to the roof. Do not nail through the lower portion of the flashing. Make weather-tight by sealing with caulking. Where possible, cover the sides and top edges of the flashing with roofing material.
- F.** Aligning the seams of the terminal and air terminal connector, place the terminal over the air terminal connector making sure the vent pipe goes into the hole in the terminal. Secure with 3 screws.
- G.** Apply a heavy bead of weatherproof caulking 2" (51mm) above the flashing. Install the storm collar around the air terminal and slide down to the caulking. Tighten to ensure that a weather-tight seal between the air terminal and the collar is achieved.
- H.** If more vent pipe needs to be used to reach the appliance see "HORIZONTAL AIR TERMINAL INSTALLATION" section.

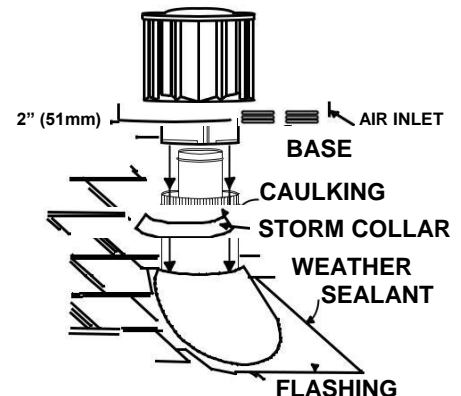
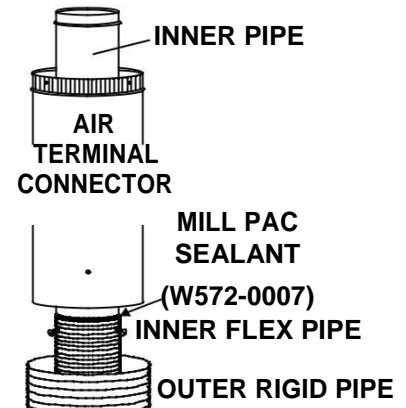
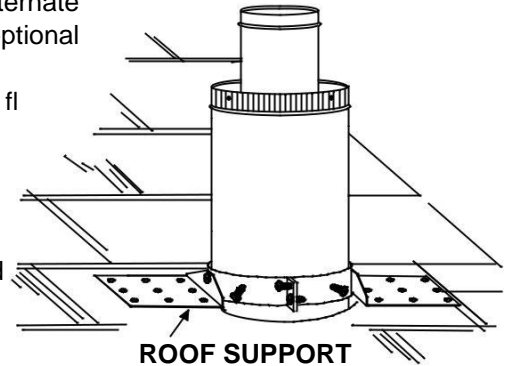

4.2.3 appliance vent connection

- A. Install the inner exhaust flue collar to the appliance. Secure with a minimum of 3 #8 screws. Seal the joint and screw holes using Mill Pac sealant (W573-0007) (not supplied).
- B. Install the outer flex pipe to the appliance. Attach and seal the joints using a red RTV silicone and a minimum of 3 #8 screws.

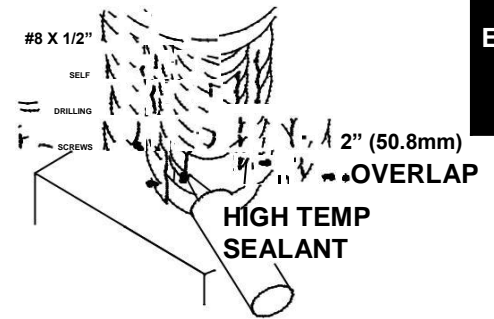

4.3 using rigid vent components

The vent system must be supported approximately every 3 feet (0.9m) for both vertical and horizontal runs. Use Wolf Steel Ltd. support ring assembly or equivalent noncombustible strapping to maintain the minimum clearance to combustibles for both vertical and horizontal runs.

All inner exhaust and outer intake vent pipe joints may be sealed using either red high temperature silicone sealant (W573-0002) (not supplied) or black high temperature sealant W573-0007 Mill Pac (not supplied) with the exception of the appliance exhaust flue collar which must be sealed using Mill Pac.

4.3.1 horizontal air terminal installation

! WARNING

RISK OF FIRE, DO NOT ALLOW LOOSE MATERIALS OR INSULATION TO TOUCH THE VENT PIPE. REMOVE INSULATION TO ALLOW FOR THE INSTALLATION OF THE ATTIC SHIELD AND TO MAINTAIN CLEARANCES TO COMBUSTIBLES.

- A. Move the appliance into position. Measure the vent length required between terminal and appliance taking into account the additional length needed for the finished wall surface and any 1" (25.4mm) overlaps between venting components.

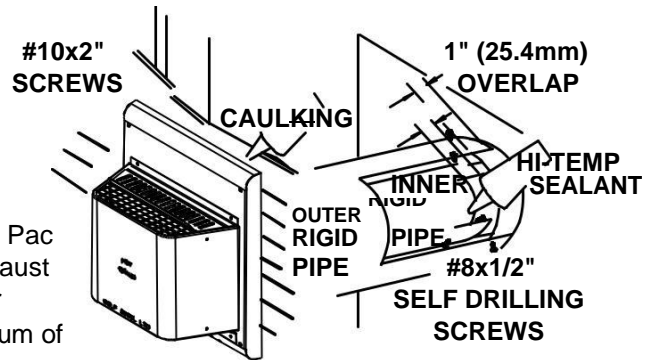

- B. Apply high temperature sealant W573-0007 Mill Pac (not supplied) to the outer edge of the inner exhaust flue collar of the appliance. Attach the first inner rigid pipe component and secure using a minimum of 3 self tapping screws. Repeat using the outer rigid pipe.
- C. Insert the vent pipes through the firestop maintaining the required clearance to combustibles. Holding the air terminal (lettering in an upright, readable position), secure to the exterior wall and make weather tight by sealing with caulking (not supplied).

The air terminal mounting plate may be recessed into the exterior wall or siding no greater than the depth of the return flange.

4.3.2 vertical air terminal installation

- A. Move the appliance into position.
- B. Fasten the roof support to the roof using the screws provided. The roof support is optional. In this case the venting is to be adequately supported using either an alternate method suitable to the authority having jurisdiction or the optional roof support.
- C. Apply high temperature sealant (not supplied) to the outer edge of the inner sleeve of the air terminal. Slip the inner coupler a minimum of 2" (51mm) over the sleeve and secure using a minimum of 3 screws.
- D. Apply high temperature sealant (not supplied) to the outer edge of the inside sleeve of the air terminal connector. Slip the outer coupler over the sleeve and secure as before. Trim the outer coupler even with the inner coupler end.

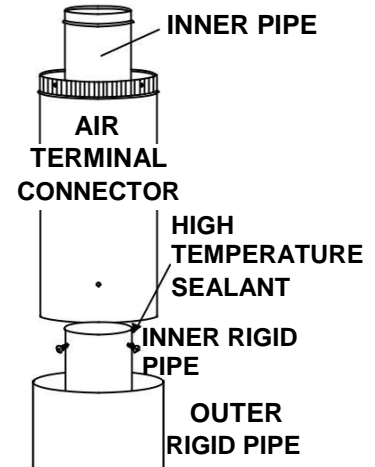

through the roof support and attach, ensuring that a minimum 16" (40.6cm) of air terminal connector will penetrate the roof when fastened. If the attic space is tight, we recommend threading the Wolf Steel vent pipe collar or equivalent loosely onto the air terminal connector / vent pipe assembly as it is passed through the attic. The air terminal connector must be located vertically and plumb.

- F. Remove nails from the shingles, above and to the sides of the air terminal connector. Place the fl ashing over the air terminal connector and slide it underneath the sides and upper edge of the shingles. Ensure that the air terminal connector is properly centered within the fl ashing, giving a 3/4" (19mm) margin all around. Fasten to the roof. Do NOT nail through the lower portion of the fl ashing. Make weather-tight by sealing with caulking. Where possible, cover the sides and top edges of the fl ashing with roofing material.
- G. Apply a heavy bead of waterproof caulking 2" (51mm) above the fl ashing. Install the storm collar around the air terminal and slide down to the caulking. Tighten to ensure that a weather-tight seal between the air terminal connector and the collar is achieved.
- H. Continue adding rigid venting sections, sealing and securing as above. Attach the inner collapsed telescopic sleeve to the last section of rigid piping. Secure with screws and seal. Repeat using the outer telescopic sleeve.
- I. Run a bead of red RTV silicone (not supplied) around the outside of the inner exhaust fl ue collar on the appliance. Pull the telescopic sleeve a minimum of 2" (51mm) onto the collar. Secure with a minimum of 3 screws. Repeat with the outer telescopic sleeve.
- J. In the attic, slide the vent pipe collar down to cover up the open end of the shield and tighten. This will prevent any materials, such as insulation, from filling up the 1" (25mm) air space around the pipe.

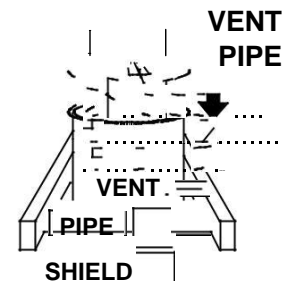

4.3.3 restricting vertical vents

! WARNING

TURN OFF GAS AND ELECTRICAL SUPPLY BEFORE SERVICING THE APPLIANCE.

APPLIANCE MAY BE HOT, DO NOT SERVICE UNTIL APPLIANCE IS COOL.

FOR SAFE AND PROPER OPERATION OF THE APPLIANCE, FOLLOW THE VENTING INSTRUCTION EXACTLY.

TO AVOID DANGER OF SUFFOCATION KEEP THE PACKAGING BAG AWAY FROM BABIES AND CHILDREN. DO NOT USE IN CRIBS, BED, CARRIAGES OR PLAY PENS. THIS BAG IS NOT A TOY. KNOT BEFORE THROWING AWAY.

Vertical installations may display an active flame. If this appearance is not desirable, the exhaust outlet may be restricted with a Wolf Steel approved restrictor kit. This kit is not recommended for short vertical vent runs.

NOTE: Depending on the model and/or year of the appliance, mounting holes may not exist.

- A. If mounting holes exist, remove the screws from the firebox top, align the restrictor plate as illustrated, and secure.
- B. If mounting holes do not exist, align the restrictor plate as illustrated and secure using the 2 #8 x 1/2 hex head sheet metal screws supplied.
- C. Ensure the plate will pivot at the slot up into the exhaust outlet.
- D. Depending on the amount of restriction desired, the restrictor plate can be left flat for most restriction or bent up for varying degrees of restriction.

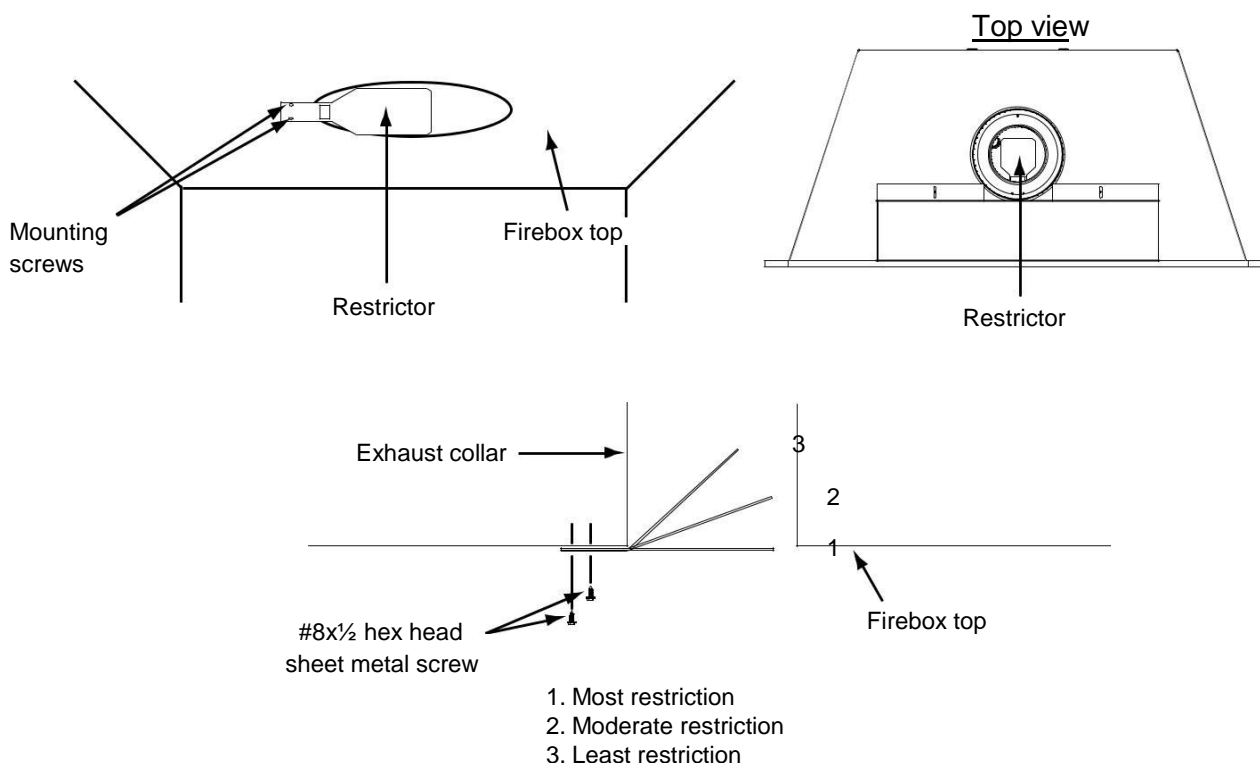

4.4 vertical through existing chimney

! WARNING

RISK OF FIRE!

CO-AXIAL TO CO-LINEAR VENTING CONFIGURATIONS MUST ONLY BE USED IN A NON-COMBUSTIBLE CHIMNEY OR ENCLOSURE. INSTALLATION IN A COMBUSTIBLE ENCLOSURE COULD RESULT IN A FIRE.

This appliance is designed to be attached to a 3" (76.2mm) co-linear aluminum fl ex vent system running the full length of a masonry chimney.

The fl ex liners accommodate any contours of a masonry chimney, however, it is necessary to keep the fl exible liners as straight as possible. The inlet air collar of the termination cap must be connected to the air intake fl ex liner and the exhaust collar must be connected to the exhaust fl exible liner.

Both Simpson Duravent and Selkirk co-linear to co-axial adaptors have been approved on this appliance

(NOTE: A vent adaptor will be required directly off the appliance).

Follow vent manufacturer's installation instructions.

Different manufacturer's venting components must not be combined. Once the preferred manufacturer's appliance adaptor has been attached, the remainder of the system must be that of the same manufacturer.

The only exception to this rule is to use Wolf Steel's approved 3" (76.2mm) fl ex liner and co-linear termination.

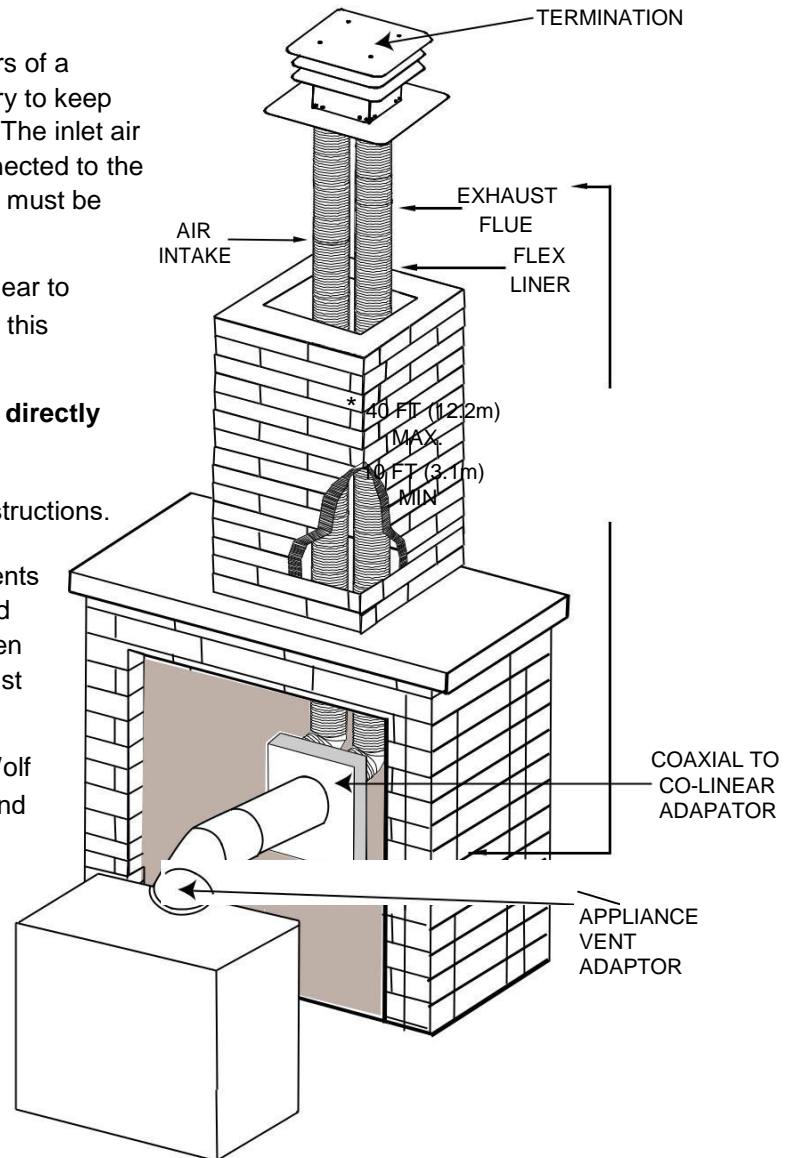

* Measured from appliance fl ue collar to termination fl ue collar

4.5 mobile home installation

This appliance must be installed in accordance with the manufacturer's instructions and the Manufactured Home Construction and Safety Standard, Title 24 CFR, Part 3280, in the United States or the Mobile Home Standard, CAN/CSA Z240 MH Series, in Canada. This appliance is only for use with the type(s) of gas indicated on the rating plate.

This Mobile/Manufactured Home Listed appliance comes factory equipped with a means to secure the appliance. Built in appliances are equipped with 1/4" (6.4mm) diameter holes located in the front left and right corners of the base. Use appropriate fasteners, inserted through the holes in the base to secure. For free standing products contact your local authorized dealer / distributor for the appropriate securing kit. For mobile home installations, the appliance must be fastened in place. It is recommended that the appliance be secured in all installations. Always turn off the pilot and the fuel supply at the source, prior to moving the mobile home. After moving the mobile home and prior to lighting the appliance, ensure that the logs are positioned correctly.

This appliance is certified to be installed in an aftermarket permanently located, manufactured (mobile) home, where not prohibited by local codes. This appliance is only for use with the type of gas indicated on the rating plate. This appliance is not convertible for use with other gases, unless a certified kit is used.

Conversion Kits

This appliance is field convertible between Natural Gas (NG) and Propane (P). To convert from one gas to another consult your Authorized dealer/distributor.

4.6 gas installation

WARNING

RISK OF FIRE, EXPLOSION OR ASPHYXIATION. ENSURE THERE ARE NO IGNITION SOURCES SUCH AS SPARKS OR OPEN FLAMES.

SUPPORT GAS CONTROL WHEN ATTACHING GAS SUPPLY PIPE TO PREVENT DAMAGING GAS LINE.

ALWAYS LIGHT THE PILOT WHETHER FOR THE FIRST TIME OR IF THE GAS SUPPLY HAS RUN OUT WITH THE GLASS DOOR OPENED OR REMOVED. PURGING OF THE GAS SUPPLY LINE SHOULD BE PERFORMED BY A QUALIFIED SERVICE TECHNICIAN. ASSURE THAT A CONTINUOUS GAS FLOW IS AT THE BURNER BEFORE CLOSING THE DOOR. ENSURE ADEQUATE VENTILATION. FOR GAS AND ELECTRICAL LOCATIONS, SEE "DIMENSIONS" SECTION.

ALL GAS CONNECTIONS MUST BE CONTAINED WITHIN THE APPLIANCE WHEN COMPLETE.

HIGH PRESSURE WILL DAMAGE VALVE. DISCONNECT GAS SUPPLY PIPING BEFORE TESTING GAS LINE AT TEST PRESSURES ABOVE 1/2 PSIG.

VALVE SETTINGS HAVE BEEN FACTORY SET, DO NOT CHANGE.

Installation and servicing to be done by a qualified installer.

- A. Move the appliance into position and secure.
- B. If equipped with a flex connector the appliance is designed to accept a 1/2" (13mm) gas supply. Without the connector it is designed to accept a 3/8" (9.5mm) gas supply. The appliance is equipped with a manual shut off valve to turn off the gas supply to the appliance.
- C. Connect the gas supply in accordance to local codes. In the absence of local codes, install to the current CAN/CSA-B149.1 Installation Code in Canada or to the current National Fuel Gas Code, ANSI Z223.1 / NFPA 54 in the United States.
- D. When flexing any gas line, support the gas valve so that the lines are not bent or kinked.
- E. The gas line flex-connector should be installed to provide sufficient movement for shifting the burner assembly on its side to aid with servicing components.
- F. Check for gas leaks by brushing on a soap and water solution. **Do not use open flame.**

4.7 optional wall switch

WARNING

DO NOT CONNECT EITHER THE WALL SWITCH, THERMOSTAT OR GAS VALVE DIRECTLY TO 110 VOLT ELECTRICITY.

For ease of accessibility, an optional remote wall switch or millivolt thermostat may be installed in a convenient location. Route a 2 strand, solid core millivolt wire from the valve to the wall switch or millivolt thermostat. The recommended maximum lead length depends on wire size:

WIRE SIZE	MAX. LENGTH
14 gauge (1.8mm)	100 feet (30.5m)
16 gauge (1.5mm)	60 feet (18.3m)
18 gauge (1.2mm)	40 feet (12.2m)

* Refer to "wiring diagram" section.

5.0 framing

NOTE: When using optional finishing accessories, the framing dimensions and finishing materials may differ from what is outlined in the section below. Refer to the leaflet instructions in the accessory kit for specific framing and finishing specifications.

5.1 framing for CB36 / CX36-1

! WARNING

RISK OF FIRE!

IN ORDER TO AVOID THE POSSIBILITY OF EXPOSED INSULATION OR VAPOUR BARRIER COMING IN CONTACT WITH THE APPLIANCE BODY, IT IS RECOMMENDED THAT THE WALLS OF THE APPLIANCE ENCLOSURE BE "FINISHED" (IE: DRYWALL / SHEETROCK), AS YOU WOULD FINISH ANY OTHER OUTSIDE WALL OF A HOME. THIS WILL ENSURE THAT CLEARANCE TO COMBUSTIBLES IS MAINTAINED WITHIN THE CAVITY.

DO NOT NOTCH THE FRAMING AROUND THE APPLIANCE STAND-OFFS. FAILURE TO MAINTAIN AIR SPACE CLEARANCE MAY CAUSE OVER HEATING AND FIRE. PREVENT CONTACT WITH SAGGING OR LOOSE INSULATION OR FRAMING AND OTHER COMBUSTIBLE MATERIALS. BLOCK OPENING INTO THE CHASE TO PREVENT ENTRY OF BLOWN-IN INSULATION. MAKE SURE INSULATION AND OTHER MATERIALS ARE SECURED.

WHEN CONSTRUCTING THE ENCLOSURE ALLOW FOR FINISHING MATERIAL THICKNESS TO MAINTAIN CLEARANCES. FRAMING OR FINISHING MATERIAL CLOSER THAN THE MINIMUMS LISTED MUST BE CONSTRUCTED ENTIRELY OF NON-COMBUSTIBLE MATERIALS. MATERIALS CONSISTING ENTIRELY OF STEEL, IRON, BRICK, TILE, CONCRETE, SLATE, GLASS OR PLASTERS, OR ANY COMBINATION THEREOF ARE SUITABLE. MATERIALS THAT ARE REPORTED AS PASSING ASTM E 136, STANDARD TEST METHOD FOR BEHAVIOUR OF MATERIALS IN A VERTICAL TUBE FURNACE AT 1382°F (750°C) AND UL763 SHALL BE CONSIDERED NON-COMBUSTIBLE MATERIALS.

MINIMUM CLEARANCE TO COMBUSTIBLES MUST BE MAINTAINED OR A SERIOUS FIRE HAZARD COULD RESULT.

THE APPLIANCE REQUIRES A MINIMUM ENCLOSURE HEIGHT. MEASURE FROM THE APPLIANCE BASE. IF STEEL STUD FRAMING KITS WITH CEMENT BOARD ARE PROVIDED, OR SPECIFIED IN THE INSTALLATION INSTRUCTIONS, THEY MUST BE INSTALLED.

IF SPECIFIED IN THE INSTALLATION INSTRUCTION FINISHING MUST BE DONE USING A NON-COMBUSTIBLE MATERIAL SUCH AS NON-COMBUSTIBLE BOARD, CERAMIC TILE, MARBLE, ETC. DO NOT USE WOOD OR DRYWALL. ANY FIRE RATED DRYWALL IS NOT ACCEPTABLE.

It is best to frame the appliance after it is positioned and the vent system is installed. Frame to local building codes.

It is not necessary to install a hearth extension with this appliance.

When roughing in the appliance, raise the appliance to accommodate for the thickness of the finished floor materials (i.e. tile, carpeting, hard wood), which if not planned for, will interfere with the opening of the lower access door and the installation of many decorative flashing accessories.

Combustible materials may be installed flush with the front of the appliance but must not cover any of the black face-areas of the appliance. Non-combustible material (i.e. brick, stone, ceramic tile) may protrude in these areas.

5.1.1 minimum framing dimensions for CB36 / CX36-1

EN

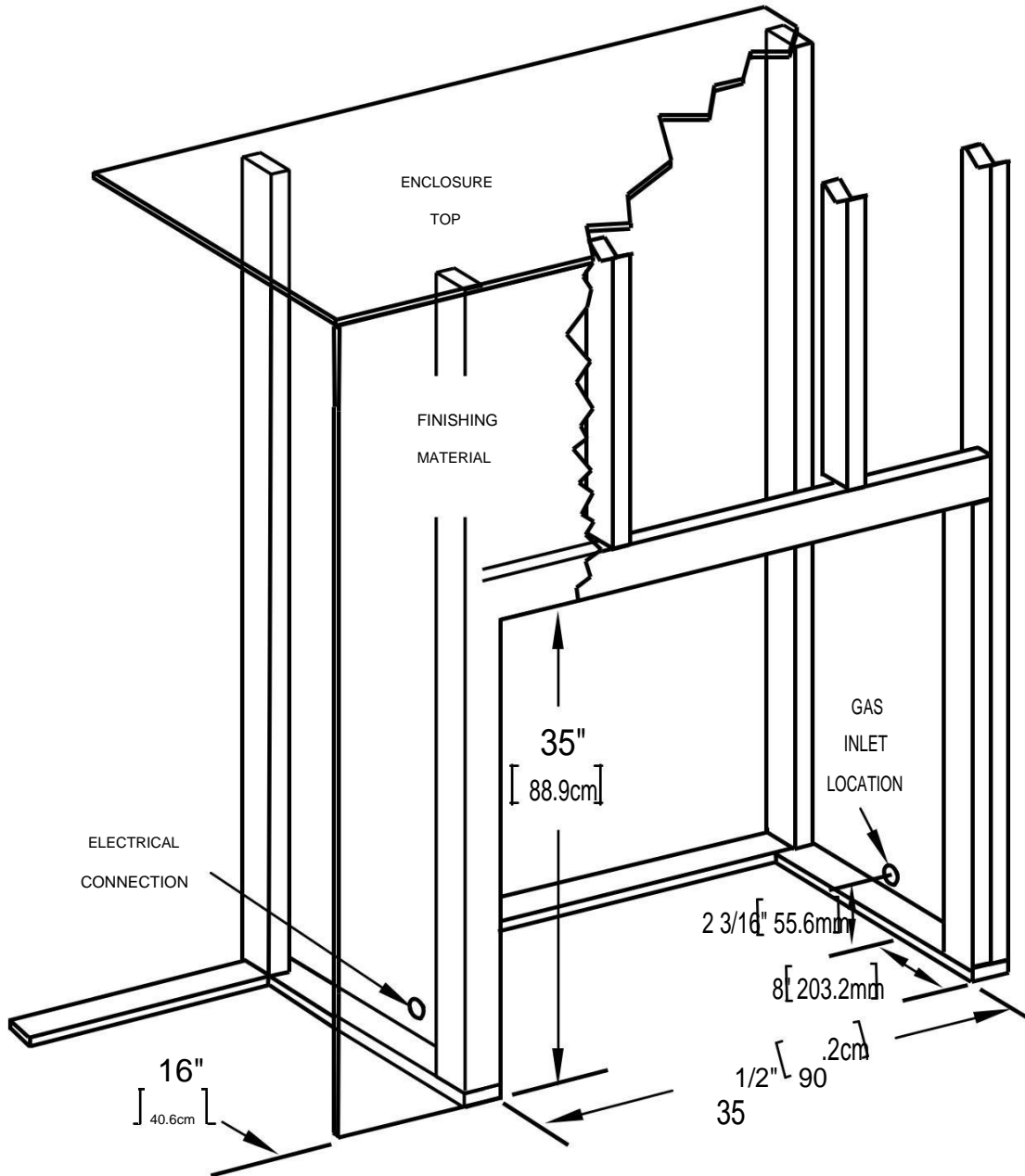

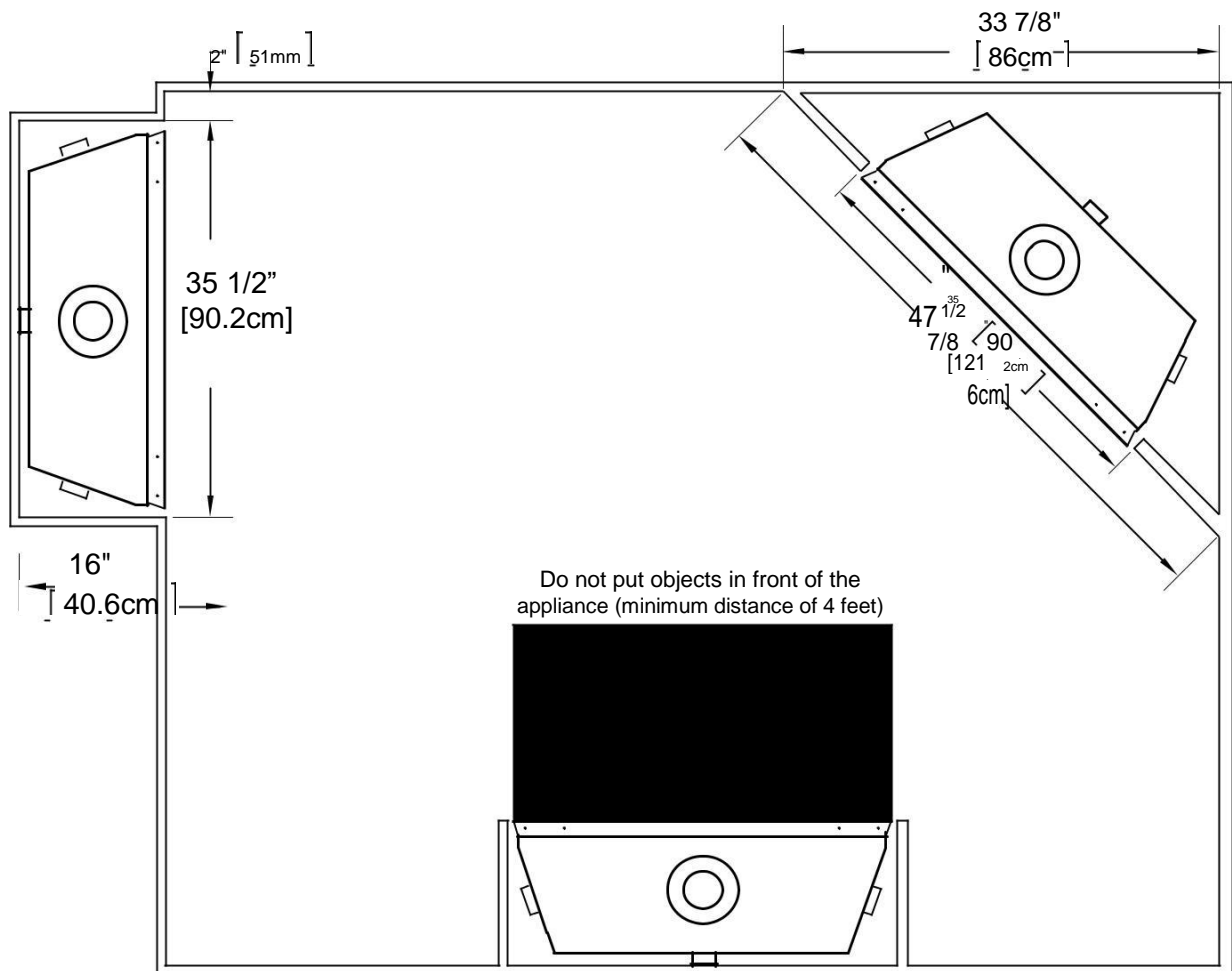

CB36 / CX36-1 HORIZONTAL VENT SECTIONS: A minimum of 1" (25mm) at the bottom and sides, and 3" (76.2mm) at the top of the vent pipe on all horizontal runs to combustibles is required. Use firestop spacer W010-3440 (supplied).

NOTE: The minimum clearances from the top of the horizontal vent pipe to combustible materials may be reduced from 3" (76.2mm) to 1" (25mm) with the CB36 OR 2" (50.8mm) with the CX36-1 in those installations with a minimum 38" (96.5cm) vertical vent rise made immediately off the appliance collar.

CB36 / CX36-1 VERTICAL VENT SECTIONS: A minimum of 1" (25mm) all around the vent pipe on all vertical runs to combustibles is required except for clearances in appliance enclosures. Vertical runs within the enclosure must maintain a 3" (76.2mm) clearance from combustibles. See "minimum enclosure clearances" sections for both CB36 and CX36-1 models. Use firestop spacer W500-0096 (not supplied).

5.2 minimum enclosure clearances

CB36 / CX36-1 TOP VENT

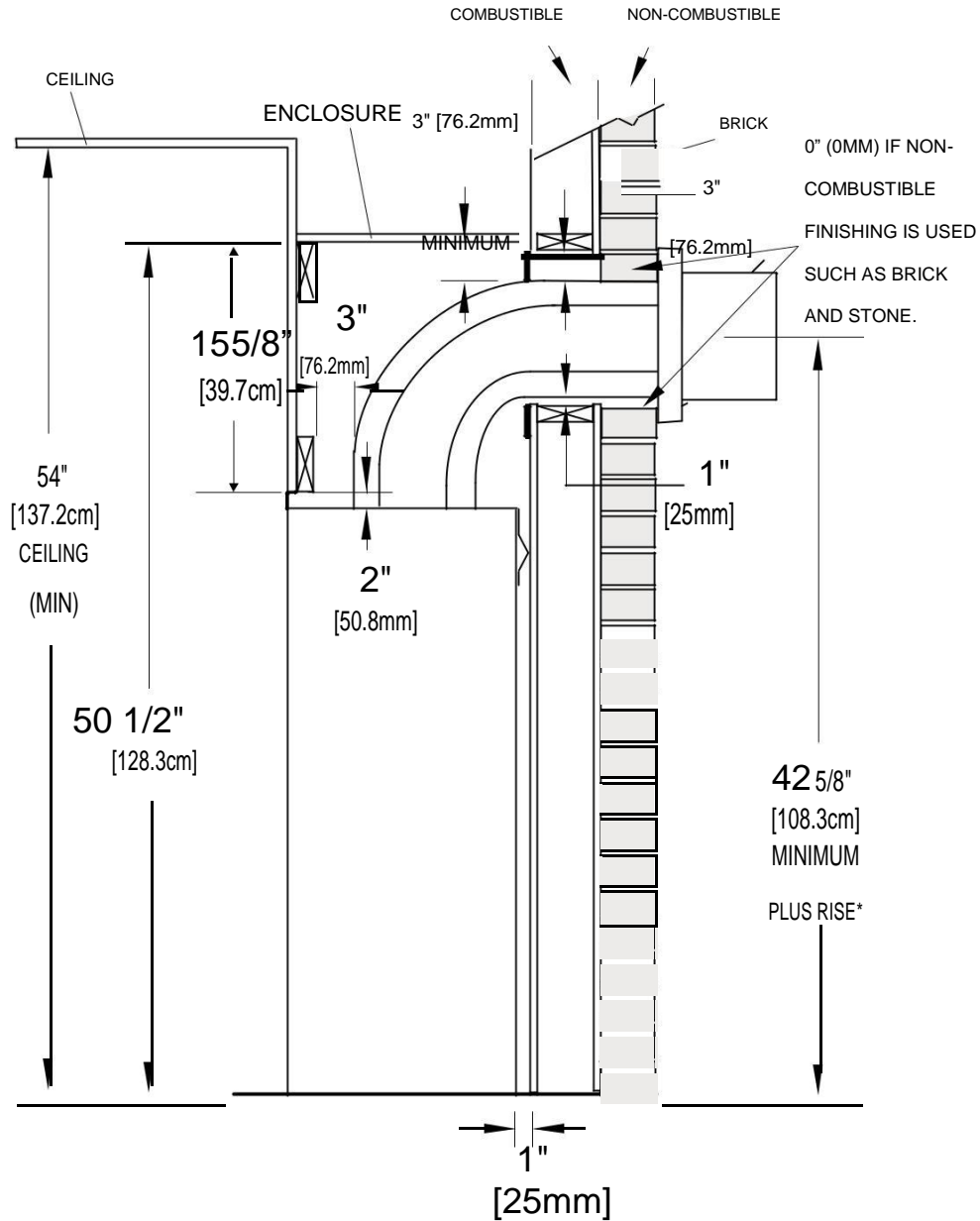

TOP EXIT ENCLOSURE

The appliance requires a minimum enclosure height of 50 1/2" (128.3cm). For temperature requirements, the enclosure space around and above the appliance must be left unobstructed.

NOTE: The vent shield is telescopic and must be adjusted to shield the full depth of the combustible wall penetration.

* See "minimum framing dimensions" section for details on reducing vent pipe top

clearances. These parameters also apply to all illustrations in this section.

CB36 / CX36-1 MINIMUM REAR VENT CLEARANCES

For rear vent termination not exceeding 10" (254mm) of horizontal vent run.

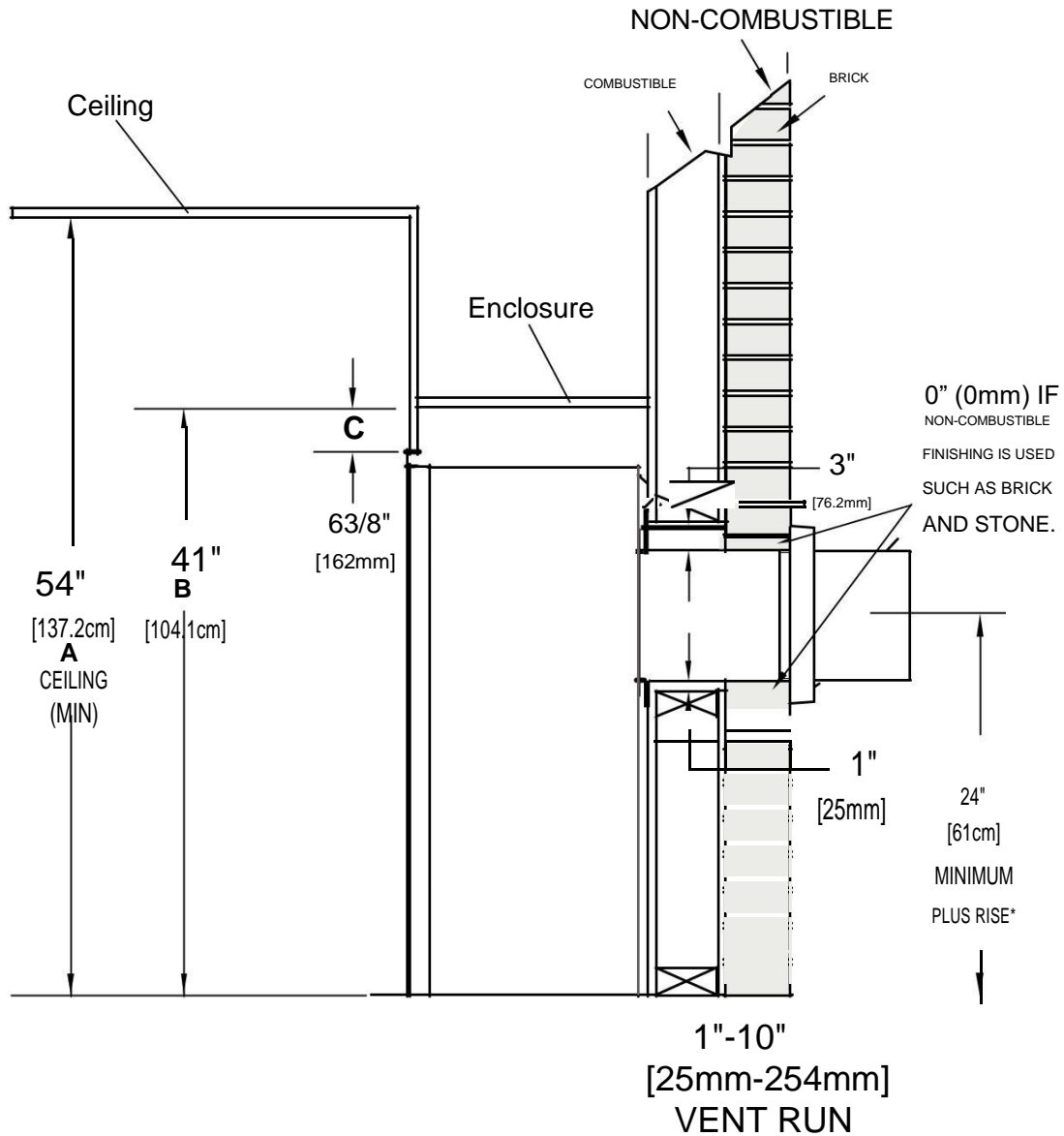

Ref.	CB36	CX36-1
A	54" (137.2cm)	54" (137.2cm)
B	41" (104.1cm)	44" (111.2cm)
C	6 3/8" (162mm)	9 3/8" (238mm)

REAR EXIT ENCLOSURE

The appliance requires a minimum enclosure height of **41" (104.1cm) for the CB36 OR 44" (111.2cm) for the CX36-1**. For temperature requirements, the enclosure space around and above the appliance must be left unobstructed.

NOTE: The vent shield is telescopic and must be adjusted to shield the full depth of the combustible wall penetration.

* See "venting" section.

CB36 / CX36-1 MAXIMUM REAR VENT CLEARANCES
(EXAMPLE 1: INTERIOR NICHE / BUMPOUT / ALCOVE)

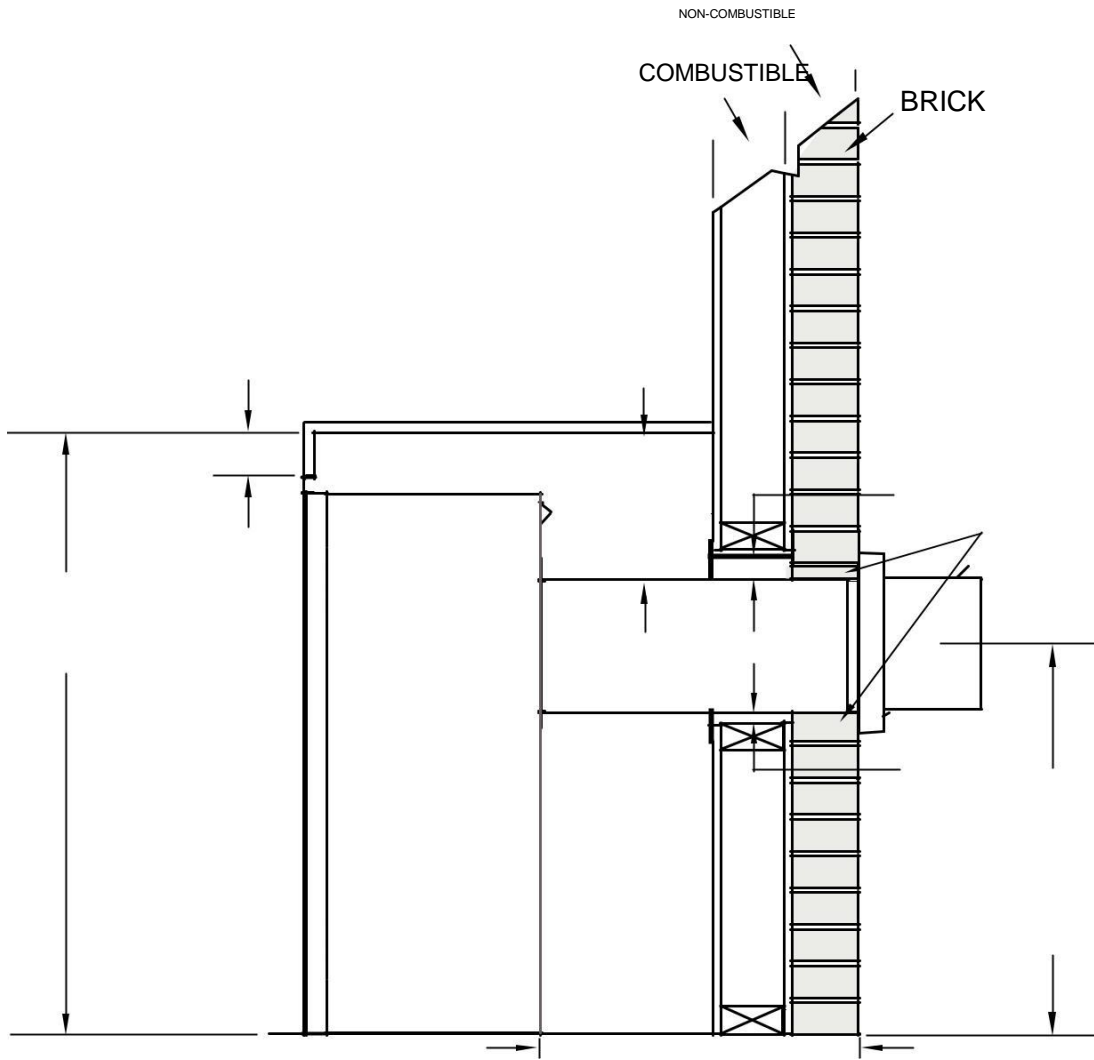

CB36 / CX36-1 MAXIMUM REAR VENT CLEARANCES
(EXAMPLE 2: EXTERIOR ALCOVE / DOGHOUSE)

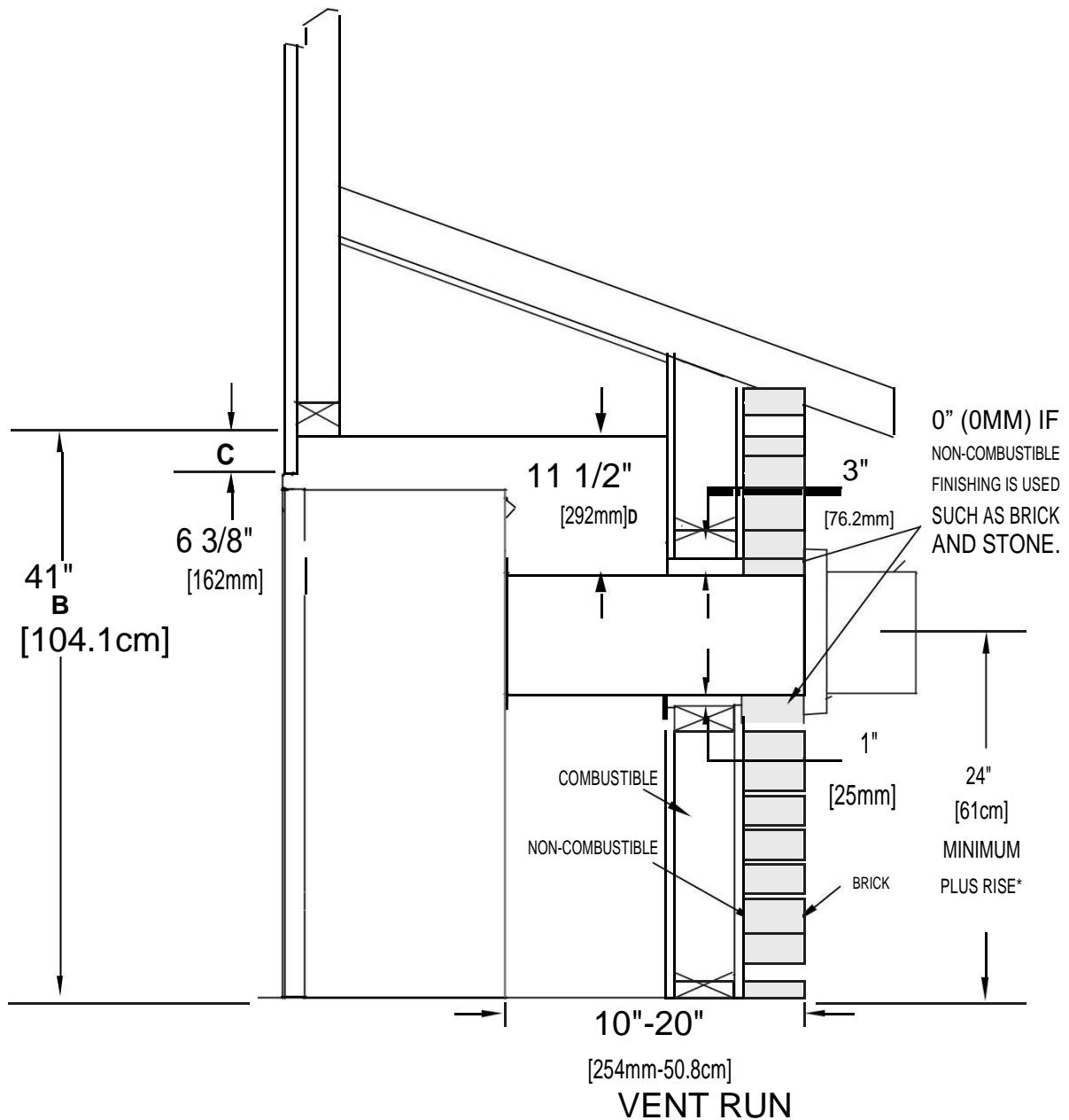

Ref.	CB36	CX36-1
B	41" (104.1cm)	44" (111.2cm)
C	6 3/8" (162mm)	9 3/8" (238mm)
D	11 1/2" (292mm)	14 1/2" (36.8cm)

REAR EXIT ENCLOSURE

The appliance requires a minimum enclosure height of **41" (104.1cm) for the CB36 OR 44" (111.2cm) for the CX36-1**. For temperature requirements, the enclosure space around and above the appliance must be left unobstructed.

NOTE: The vent shield is telescopic and must be adjusted to shield the full depth of the combustibles wall penetration.

* See "venting" section.

5.3 non-combustible facing material for CB36 / CX36-1

WARNING: Non-combustible facing material must not project more than 4" (101.6mm) from the face of the door (all three sides). If greater projections are desired, increase the clearance to the sides and top by 2" (50.8mm) for every additional 1" (25mm) of projection. If using an optional surround, the same rule applies, starting from the top of the surround. Ensure clearances are maintained for surround removal, as it must lift off the appliance for maintenance.

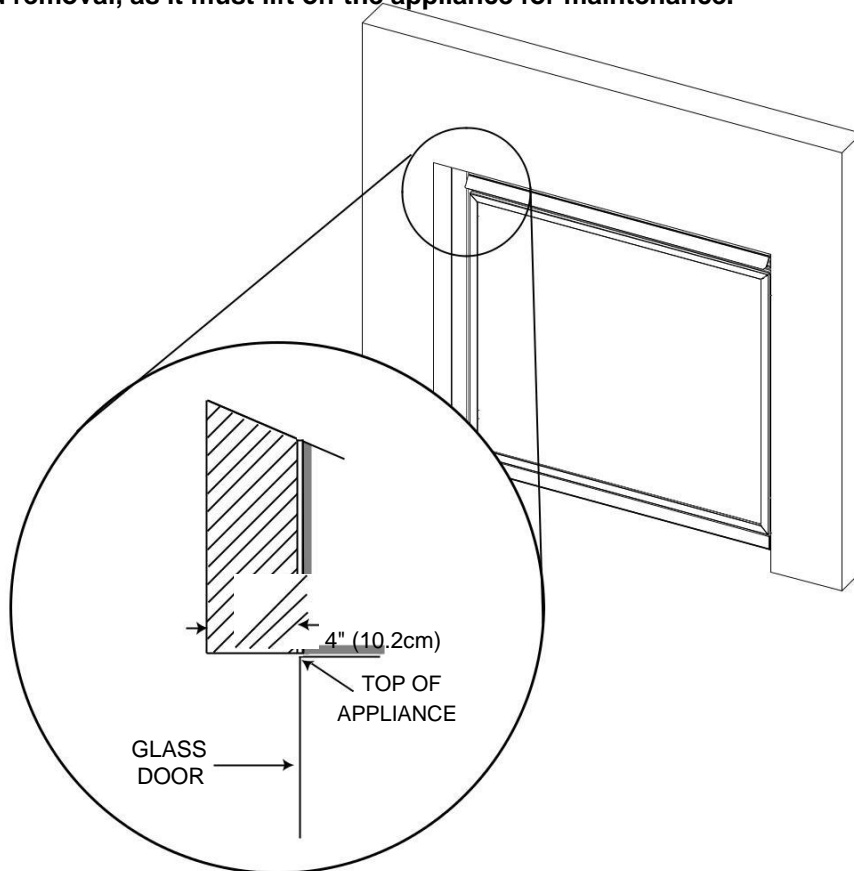

5.4 alcove clearances

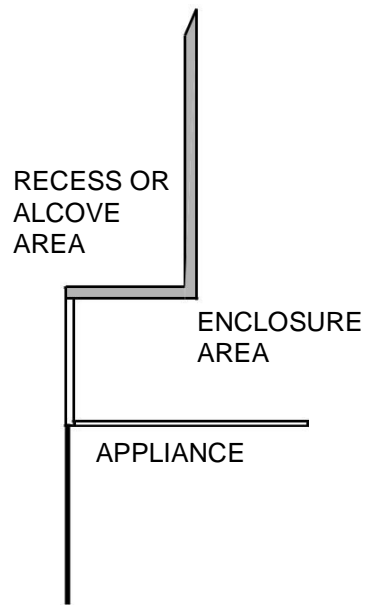

NOTE: Recesses or alcoves above the appliance can be made as deep as desired provided the minimum clearances to combustibles are maintained.

Non-combustible material can be used, provided the minimum clearances to combustible materials are applied. The minimum enclosure volume must be increased by no less than the volume of the recess. This adjustment can be made by increasing any or all of the height, width and depth of the enclosure.

5.5 recessed installation

! WARNING

INSTALLING A TELEVISION OR OTHER ELECTRONICS ABOVE THE APPLIANCE MAY CAUSE DISCOLOURATION, MELTING OR DAMAGE TO THE ELECTRONICS. USE CLEARANCES AS GUIDELINES AND REFER TO YOUR MANUFACTURER'S INSTRUCTIONS FOR FURTHER INFORMATION.

EN

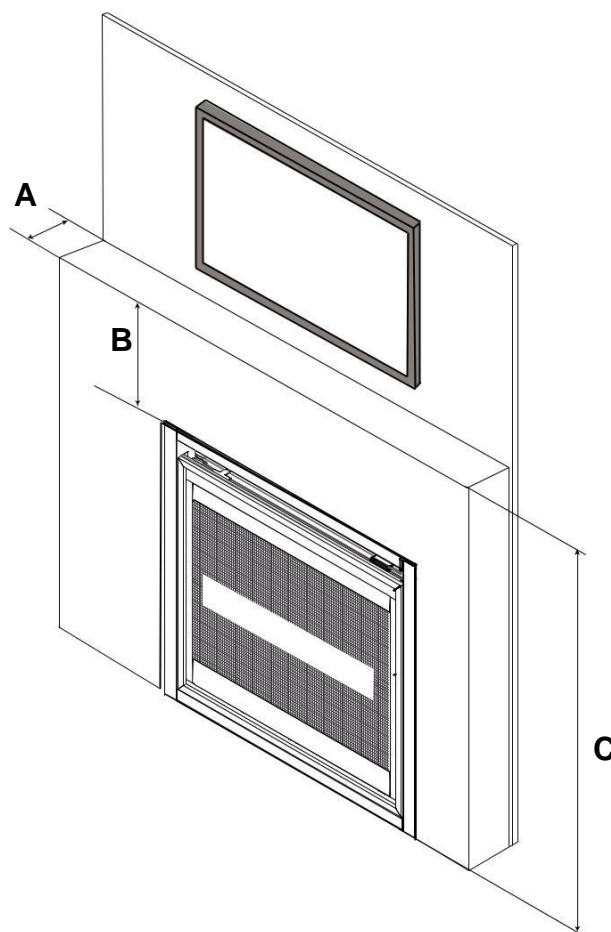

CLEARANCES CHART	
A	6" (152.4mm) MAX
B	10" (254mm) MIN
C	44" (1.11m) MIN (REAR VENT) for CX36-1 41" (1.04m) MIN (REAR VENT) for CB36
C	50 1/2" (1.28m) (TOP VENT)

Before placing anything above a heat source, it is advisable to follow proper clearances and manufacturer's instructions.

When a mantel is installed between the appliance and an electronic device or other materials, the effect of direct heat on the electronics or other materials will be reduced. Follow mantel height and depth instructions for proper clearances (see "minimum mantel clearances" section).

NOTE: Increasing the horizontal length of the mantel will further reduce the intensity of heat on the electronics.

5.6 minimum mantel clearances

! WARNING

RISK OF FIRE, MAINTAIN ALL SPECIFIED AIR SPACE CLEARANCES TO COMBUSTIBLES. FAILURE TO COMPLY WITH THESE INSTRUCTIONS MAY CAUSE A FIRE OR CAUSE THE APPLIANCE TO OVERHEAT. ENSURE ALL CLEARANCES (I.E. BACK, SIDE, TOP, VENT, MANTEL, FRONT, ETC.) ARE CLEARLY MAINTAINED.

WHEN USING PAINT OR LACQUER TO FINISH THE MANTEL, THE PAINT OR LACQUER MUST BE HEAT RESISTANT TO PREVENT DISCOLOURATION.

Combustible mantel clearance can vary according to mantel depth. Use the graph to help evaluate the clearance needed. These same requirements apply to any combustibles protruding on either side of the appliance.

LT
EH
TG
NI12" (30.5cm)
AE
MH

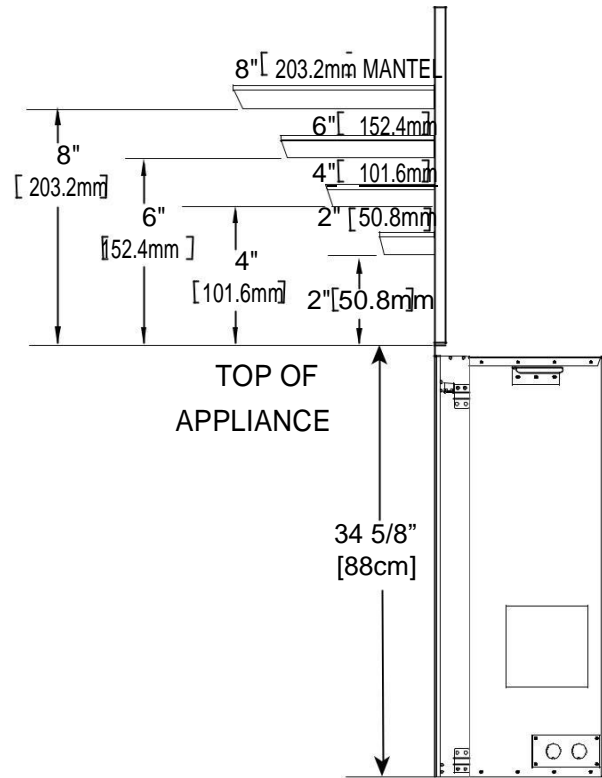
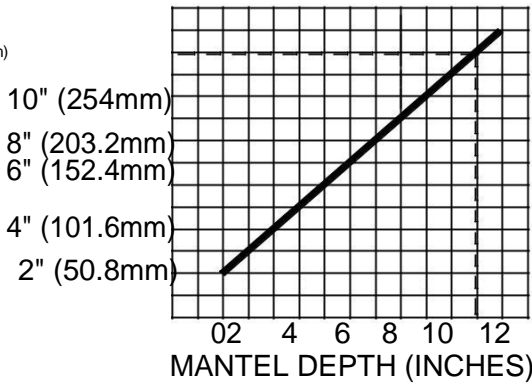

5.7 nailing tab installation

- A. To determine the final location and where to bend the nailing tabs you must first determine the thickness of your finishing material (i.e. drywall). This will determine the dimension from the front edge of the corner post to the nailing tab. Once the desired tab has been chosen, bend and secure to the framing.

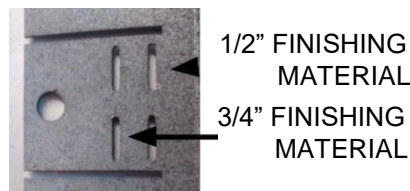

6.0 finishing

	! WARNING
RISK OF FIRE!	
NEVER OBSTRUCT THE FRONT OPENING OF THE APPLIANCE.	
IF FINISHING THE FRONT OF THE APPLIANCE, IT MUST BE FINISHED WITH ANY NON-COMBUSTIBLE MATERIAL SUCH AS BRICK, MARBLE, GRANITE, ETC.	
DO NOT STRIKE, SLAM OR SCRATCH GLASS. DO NOT OPERATE APPLIANCE WITH GLASS REMOVED, CRACKED, BROKEN OR SCRATCHED.	
FACING AND/OR FINISHING MATERIAL MUST NEVER OVERHANG INTO THE APPLIANCE OPENING	

EN

6.1 safety barrier & door removal / installation

	! WARNING
GLASS MAY BE HOT, DO NOT TOUCH GLASS UNTIL COOLED.	
IF EQUIPPED WITH DOOR LATCHES THAT ARE PART OF A SAFETY RELIEF SYSTEM, THEY MUST BE PROPERLY ENGAGED. DO NOT OPERATE THE APPLIANCE WITH LATCHES DISENGAGED. FACING	
AND/OR FINISHING MATERIALS MUST NOT INTERFERE WITH AIR FLOW THROUGH AIR OPENINGS, LOUVRE OPENINGS, OPERATION OF LOUVRES OR DOORS OR ACCESS FOR SERVICE. OBSERVE ALL CLEARANCES WHEN APPLYING COMBUSTIBLE MATERIALS.	
BEFORE DOOR IS REMOVED TURN THE APPLIANCE OFF AND WAIT UNTIL APPLIANCE IS COOL TO THE TOUCH. DOORS ARE HEAVY AND FRAGILE SO HANDLE WITH CARE.	

A barrier designed to reduce the risk of burns from the hot viewing glass is provided with the appliance and must be installed.

Before the glass door can be removed, the safety barrier must be removed. Lift the safety barrier off the 4 pins, tilt the top forward, and remove from the appliance.

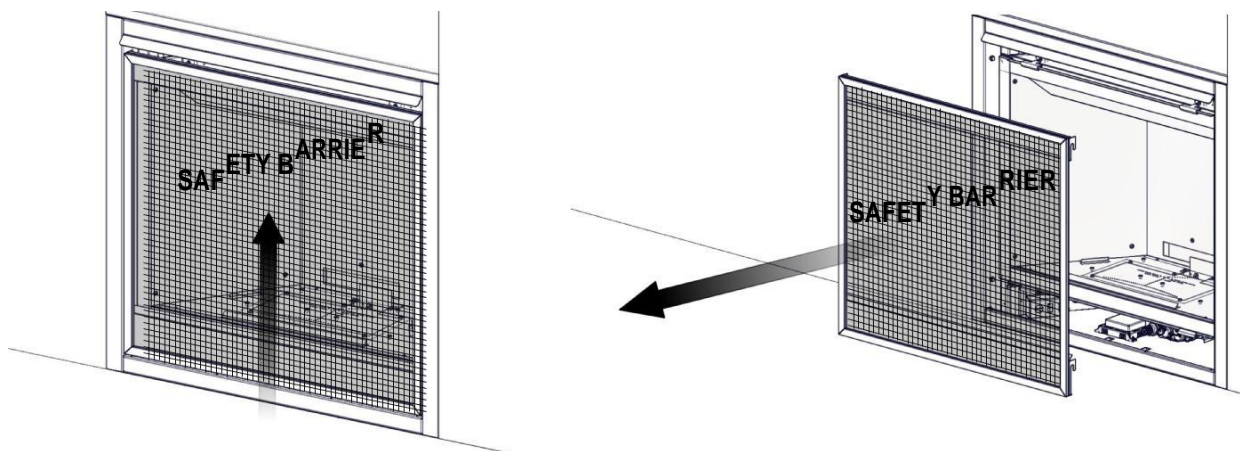

Leave a hand on the glass door during the entire door removal. The glass door is secured to the firebox with 2 spring latches along the top and 2 along the bottom. Pull the handles of the latches forward, then lift the latches out from the door frame to release the top of the door. Repeat the same step for the 2 bottom latches. Next, pivot the door forward until the top edge clears the front of the appliance. Carefully grip the sides of the door, lifting it off the appliance.

NOTE: The spring latches constitute the spring relief system for the appliance. Ensure they open freely and close with a tight seal.

Reverse these steps to reinstall the safety barrier and door. Ensure safety barrier is installed correctly.

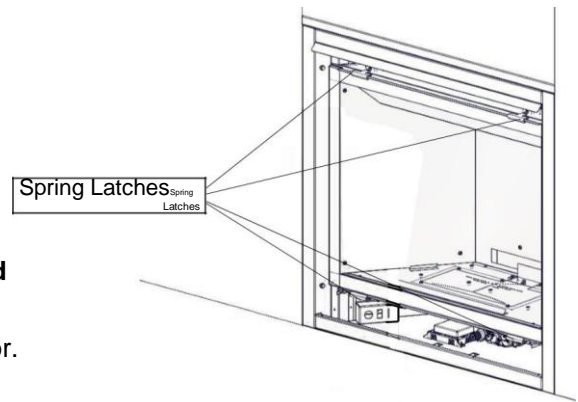

6.2 front hood installation

NOTE: This hood **MUST** be installed if it has not already been factory installed.

NOTE: Safety barrier and glass door must be removed before beginning installation.

- A. Remove the 4 securing screws from the top of the firebox (FIG 1).
- B. Install the front hood, ensuring it is angled downwards (FIG 2, 3).
- C. Reinstall the securing screws from Step A (FIG 4).

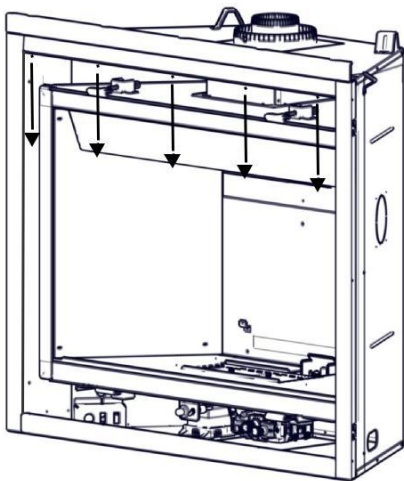

FIG. 1

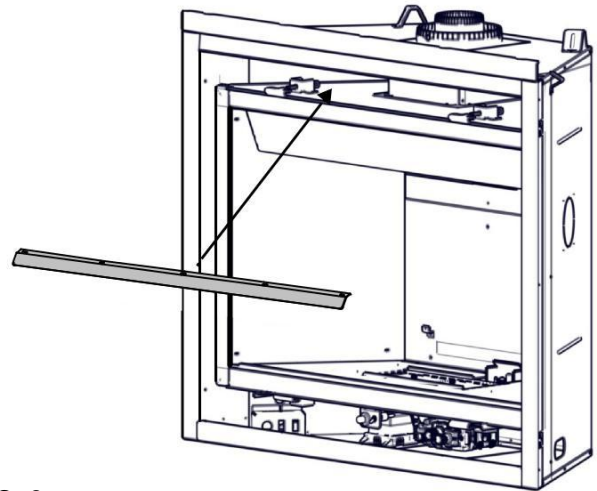

FIG. 2

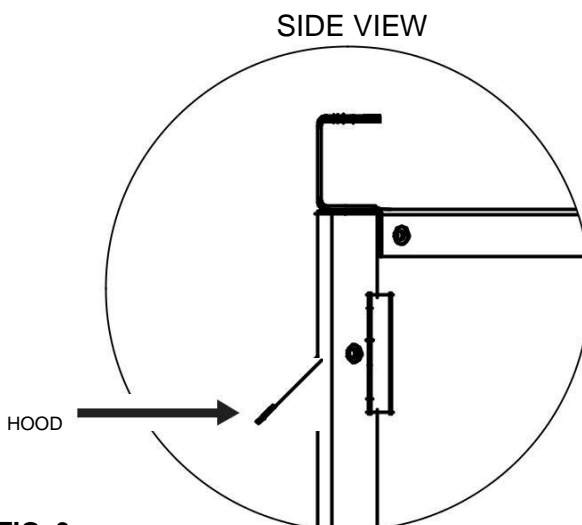

FIG. 3

W415-1679 / D / 03.09.18

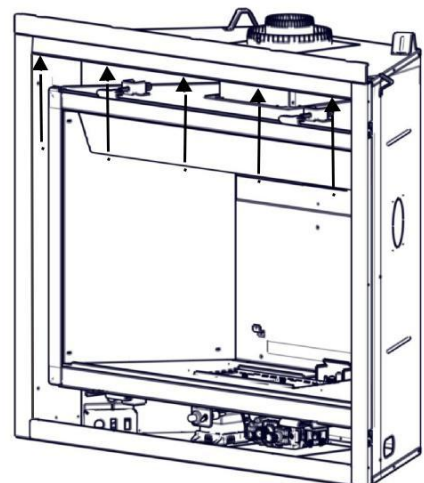

FIG. 4

6.3 CB36 / CX36-1 log placement

! WARNING

FAILURE TO POSITION THE LOGS IN ACCORDANCE WITH THESE DIAGRAMS OR FAILURE TO USE ONLY LOGS SPECIFICALLY APPROVED WITH THIS APPLIANCE MAY RESULT IN PROPERTY DAMAGE OR PERSONAL INJURY.

LOGS MUST BE PLACED IN THEIR EXACT LOCATION IN THE APPLIANCE. DO NOT MODIFY THE PROPER LOG POSITIONS, SINCE APPLIANCE MAY NOT FUNCTION PROPERLY AND DELAYED IGNITION MAY OCCUR.

THE LOGS ARE FRAGILE AND SHOULD BE HANDLED WITH CARE.

EN

PHAZER™ logs and glowing embers, exclusive to Continental, provide a unique and realistic glowing effect that is different in every installation. Take the time to carefully position the glowing embers for a maximum glowing effect. Log colours may vary. During the initial use of the appliance, the colours will become more uniform as colour pigments burn in during the heat-activated curing process.

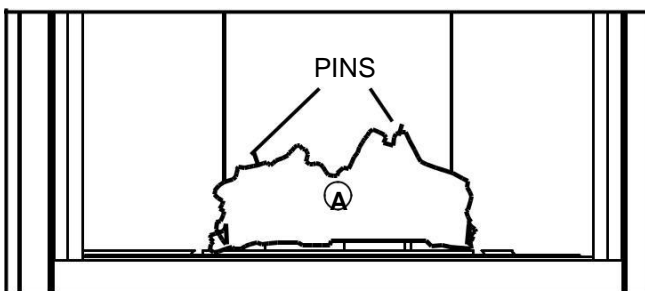

- A. Place the rear log (W135-0643) (A) firmly onto the 2 studs at the rear of the support tray. Ensure the log sits flat and does not cover the pilot opening. Place 2 pins in the holes located on the top rear of the rear log (A).

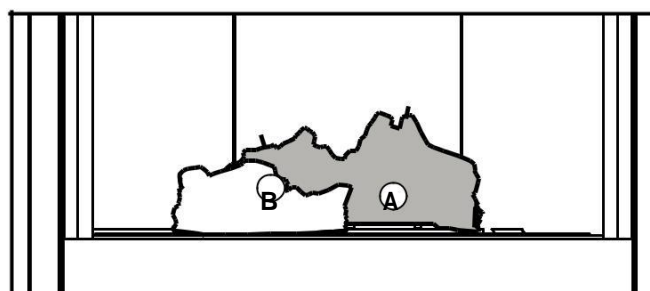

- B. Place the left front log (W135-0644) (B) onto the studs located on the left side of the log support.

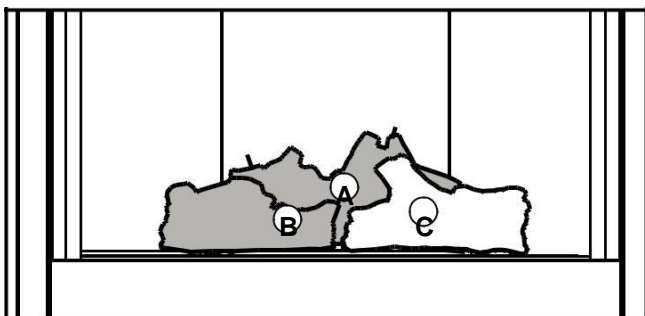

- C. Position the right front log (W135-0645) (C) onto the 2 studs located on the right side of the log support.

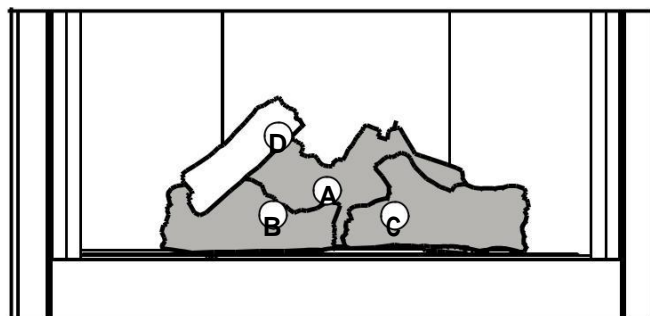

- D. Place the left crossover log (W135-0546) (D) onto the pin located in the left side of the rear log (A), allowing it to rest in the notch of the left front log (B).

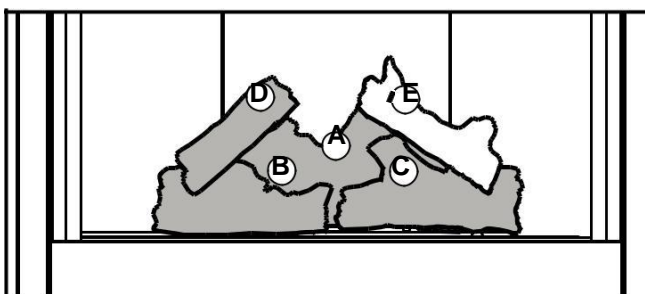

- E. Place the right crossover log (W135-0589) (E) onto the pin located in the right side of the rear log (A), allowing it to rest in the notch of the right log (C).

- F. Install the glowing embers and charcoal embers (see "glowing embers" and "charcoal embers" sections).
- G. Reinstall the door and safety barrier (see "safety barrier & door removal/installation" section).

6.4 charcoal embers

! WARNING

CHARCOAL EMBERS, VERMICULITE AND CHARCOAL LUMPS ARE NOT TO BE PLACED ON THE BURNER.

Randomly place the charcoal embers along the front and sides of the log support tray in a realistic manner. **Fine dust found in the bottom of the bag should not be used.**

NOTE: Charcoal embers are not to be placed on the burner.

6.5 glowing embers

Tear the embers into pieces and place along the front row of ports covering all of the burner area in front of the small logs. Care should be taken to shred the embers into thin, small, irregular pieces as only the exposed edges of the fibre hairs will glow. **The ember material will only glow when exposed to direct flame.**

However, care should be taken to not block the burner ports.

Blocked burner ports can cause an incorrect flame pattern, carbon deposits, and delayed ignition.

PHAZER™ logs glow when exposed to direct flame. Use only certified "glowing embers" and **PHAZER™** logs available from your authorized dealer / distributor.

6.6 battery back-up installation

! WARNING

ENSURE THE GAS AND ELECTRICAL POWER TO THE APPLIANCE IS TURNED OFF.

APPLIANCE MAY BE HOT, DO NOT SERVICE UNTIL THE APPLIANCE HAS COOLED.

NOTE: In the event of a power failure, the appliance can be operated using the supplied battery back-up.

- A. Before beginning installation, disconnect the gas and electrical power supply from the appliance.
- B. Locate the supplied battery housing.
- C. Install 4 "AA" batteries (not supplied) into the battery housing, ensuring the positive and negative ends correspond with those identified on the holder. (To open the battery housing, slide the back piece upwards and off of the battery housing).
- D. Remove the safety barrier to easily access the control compartment.
- E. Attach the wire labelled "BATTERY" from the wiring harness, located in the control compartment of the appliance, to the battery housing.
- F. Place the battery housing into the control compartment, ensuring that the battery housing is placed in a clean and easily accessible location.
- G. Reinstall the safety barrier. The safety barrier must be installed at all times during appliance operation.
- H. Turn the gas and electrical power back on to operate appliance.

NOTE: Once the power has been restored, remove the batteries from the holder. The system will drain the batteries if they are left in the battery holder.

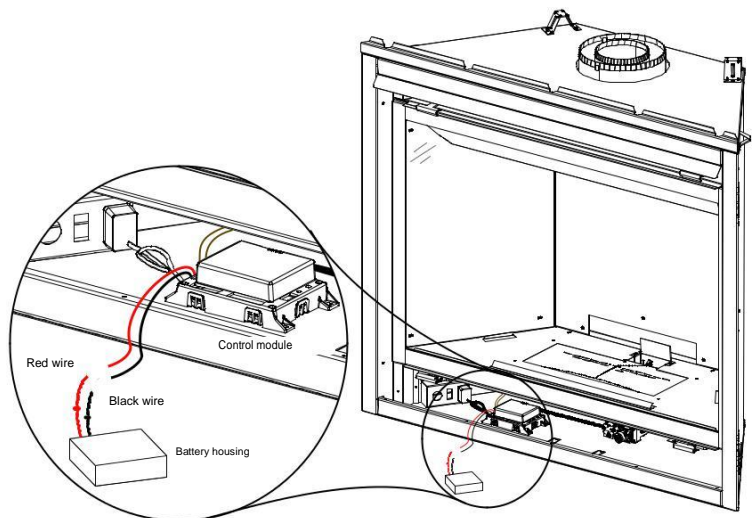

7.0 wiring diagram

7.1 wiring requirements for CB36 / CX36-1

This appliance must be electrically connected and grounded in accordance with local codes. In the absence of local codes, use the current CSA C22.1 Canadian Electrical Code in Canada or the ANSI/NFPA 70-1996 National Electrical Code in the United States.

It is necessary to hard wire this appliance. Permanently framing the appliances with an enclosure requires the appliances' junction boxes to be hard wired. This appliance must be electrically connected and grounded in accordance with local codes. In the absence of local codes, use the current CSA C22.1 Canadian electrical code in Canada or the ANSI/NFPA 70-1996 national electrical code in the United States.

7.2 CB36 electronic wiring diagram

! WARNING

DO NOT WIRE 110 VOLTS TO THE VALVE OR WALL SWITCH

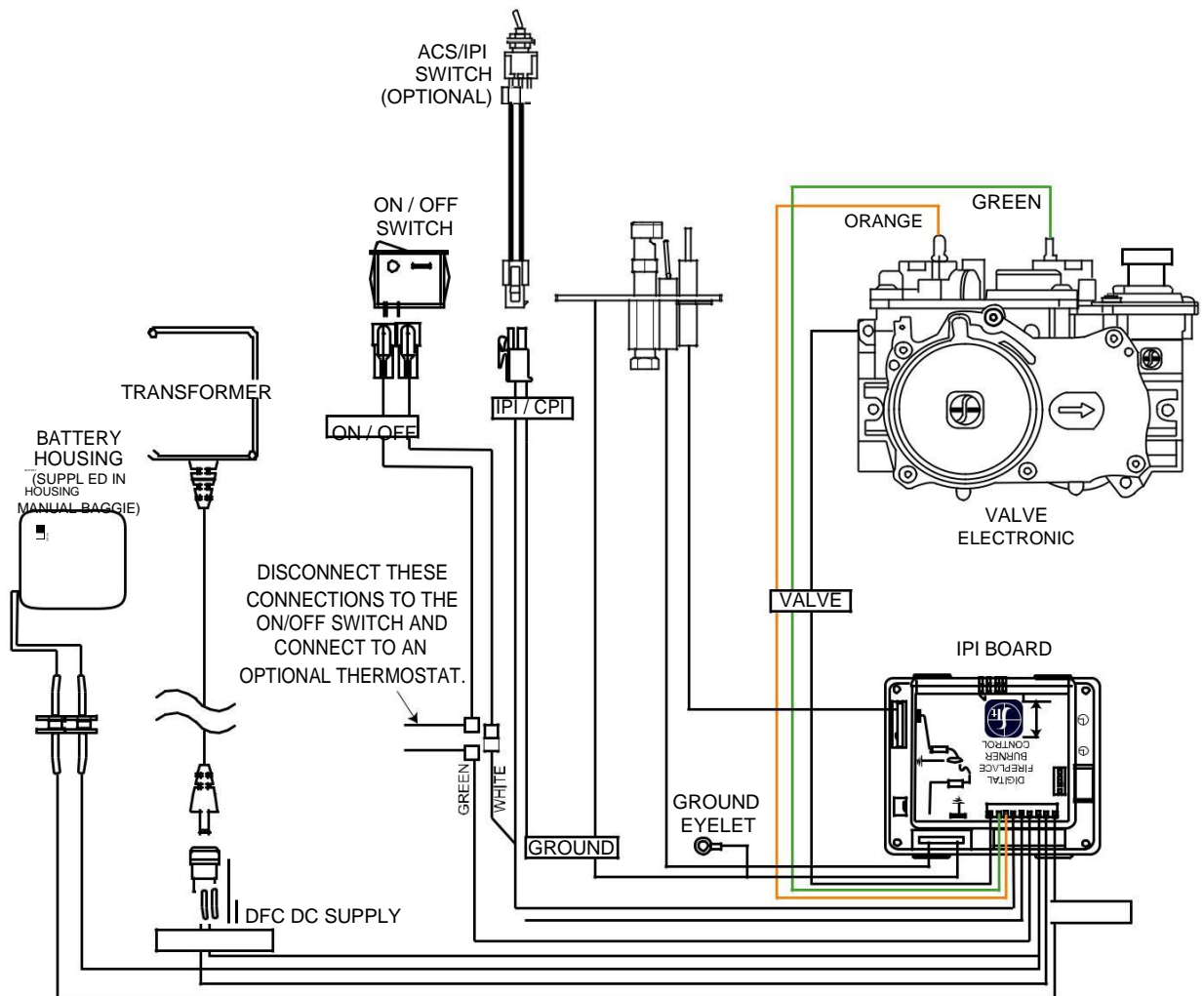

NOTE: The battery housing was supplied with the appliance. In an event of a power failure, install 4 'AA' batteries (not supplied) in the housing and attach to wire harness as illustrated above.

Legend	
DFC	Digital Fireplace Control
DC	Direct Current
IPI	Intermittent Pilot Ignition
CPI	Continuous Pilot Ignition
ACS	Anti-Condensation Switch

7.3 CX36-1 electronic wiring diagram

EN

! WARNING

DO NOT USE THIS APPLIANCE IF ANY PART HAS BEEN UNDER WATER. CALL A QUALIFIED SERVICE TECHNICIAN IMMEDIATELY TO HAVE THE APPLIANCE INSPECTED FOR DAMAGE TO THE ELECTRICAL CIRCUIT.

RISK OF ELECTRICAL SHOCK OR EXPLOSION. DO NOT WIRE 110V TO THE VALVE OR TO THE APPLIANCE WALL SWITCH. INCORRECT WIRING WILL DAMAGE CONTROLS.

ALL WIRING SHOULD BE DONE BY A QUALIFIED ELECTRICIAN AND SHALL BE IN COMPLIANCE WITH LOCAL CODES. IN THE ABSENCE OF LOCAL CODES, USE THE CURRENT CSA22.1 CANADIAN ELECTRIC CODE IN CANADA OR THE CURRENT NATIONAL ELECTRIC CODE ANSI/NFPA NO. 70 IN THE UNITED STATES.

ALWAYS LIGHT THE PILOT WHETHER FOR THE FIRST TIME OR IF THE GAS SUPPLY HAS RUN OUT, WITH THE GLASS DOOR OPENED OR REMOVED.

! WARNING

DO NOT WIRE 110 VOLTS TO THE VALVE OR WALL SWITCH.

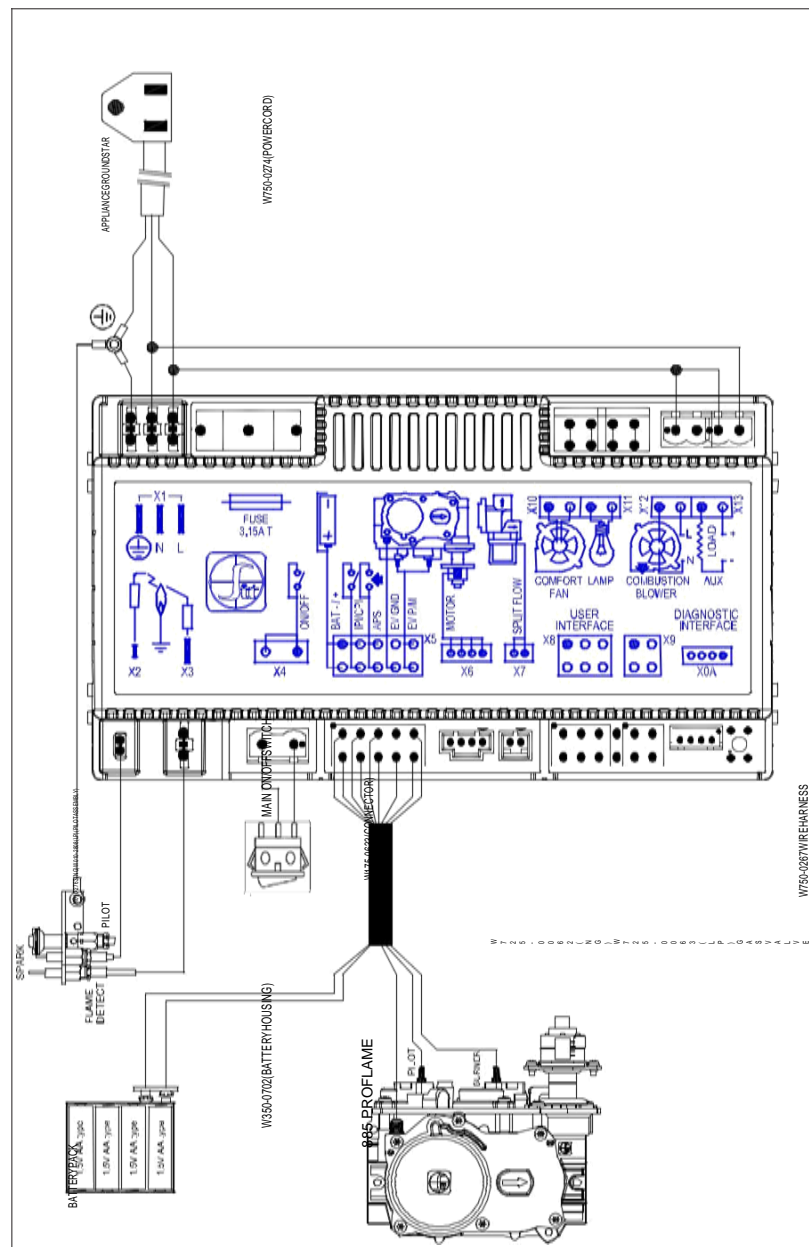

8.0 operation (electronic)

CB36NTRE/CX36NTRE-1 & CB36PTRE/CX36PTRE-1

! WARNING

IF YOU DO NOT FOLLOW THESE INSTRUCTIONS EXACTLY, A FIRE OR EXPLOSION MAY RESULT CAUSING PROPERTY DAMAGE, PERSONAL INJURY OR LOSS OF LIFE.

ALWAYS LIGHT THE PILOT WHETHER FOR THE FIRST TIME OR IF THE GAS SUPPLY HAS RUN OUT WITH THE GLASS DOOR OPENED OR REMOVED.

Ensure that a continuous gas flow is at the burner before installing the door. When lit for the first time, the appliance will emit an odor for a few hours. This is a normal temporary condition caused by the "burn-in" of paints and lubricants used in the manufacturing process and will not occur again. After extended periods of non-operation such as following a vacation or a warm weather season, the appliance may emit a slight odor for a few hours. This is caused by dust particles in the heat exchanger burning off. In both cases, open a window to sufficiently ventilate the room.

FOR YOUR SAFETY READ BEFORE LIGHTING:

Do not turn on if children or other at risk individuals are near the appliance.

Before operating smell all around the appliance area for gas and next to the floor because some gas is heavier than air and will settle on the floor.

Use only your hand to turn the gas control knob. Never use tools. If the knob will not turn by hand, do not try to repair it. Call a qualified service technician. Force or attempted repair may result in a fire or explosion.

Do not use this appliance if any part has been under water. Immediately call a qualified service technician to inspect the appliance and replace any part of the control system and any gas control which has been underwater.

WHAT TO DO IF YOU SMELL GAS:

Turn off all gas to the appliance.
Open windows.
Do not try to light any appliance.
Do not touch any electric switch; do not use any phone in your building.

Immediately call your gas supplier from a neighbour's phone. Follow the gas supplier's instructions.
If you cannot reach your gas supplier, call the fire department.



GAS KNOB

LIGHTING INSTRUCTIONS:

- A. Stop! Read the above safety information on this label
- B. Turn off all electrical power to the appliance.
- C. This appliance is equipped with an ignition device which automatically lights the pilot. Do not try to light the pilot by hand.
- D. Open the glass door.
- E. Turn manual shutoff valve clockwise to "OFF".
- F. Wait five (5) minutes to clear out any gas. If you smell gas including near the floor, **STOP!** Follow the above safety information on this label. If you don't smell gas go to the next step.
- G. Turn manual shutoff valve counter-clockwise to on.
- H. Close the glass door.
- I. Turn on all electric power to the appliance, you should hear an audible beep.
- J. Turn your appliance to the "ON" position; this can be done using the wall switch, thermostat or the remote control (optional), if equipped.

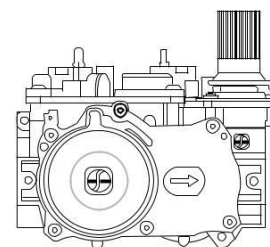

TO TURN OFF GAS:

- A. Turn off all electric power to the replace if service is to be performed.
- B. Turn manual shutoff valve clockwise to "OFF".

9.0 operation (millivolt)

CB36NTR/CX36NTR-1 & CB36PTR/CX36PTR-1

WARNING

IF YOU DO NOT FOLLOW THESE INSTRUCTIONS EXACTLY, A FIRE OR EXPLOSION MAY RESULT CAUSING PROPERTY DAMAGE, PERSONAL INJURY OR LOSS OF LIFE.

ALWAYS LIGHT THE PILOT WHETHER FOR THE FIRST TIME OR IF THE GAS SUPPLY HAS RUN OUT WITH THE GLASS DOOR OPENED OR REMOVED.

Ensure that a continuous gas flow is at the burner before installing the door. When lit for the first time, the appliance will emit an odor for a few hours. This is a normal temporary condition caused by the "burn-in" of paints and lubricants used in the manufacturing process and will not occur again.

After extended periods of non-operation such as following a vacation or a warm weather season, the appliance may emit a slight odor for a few hours. This is caused by dust particles in the heat exchanger burning off. In both cases, open a window to sufficiently ventilate the room.

FOR YOUR SAFETY READ BEFORE LIGHTING:

- This appliance is equipped with a pilot which must be lit by hand while following these instructions exactly.
- Before operating smell all around the appliance area for gas and next to the floor because some gas is heavier than air and will settle on the floor.
- Use only your hand to turn the gas control knob. Never use tools. If the knob will not turn by hand, do not try to repair it. Call a qualified service technician. Force or attempted repair may result in a fire or explosion.
- Do not use this appliance if any part has been under water. Immediately call a qualified service technician to inspect the appliance and replace any part of the control system and any gas control which has been under water.

WHAT TO DO IF YOU SMELL GAS:



- | | |
|--|---|
| • Turn off all gas to the appliance. | • Immediately call your gas supplier from a neighbor's phone. Follow the gas supplier's instructions. |
| • Open windows. | • If you cannot reach your gas supplier, call the fire department. |
| • Do not try to light any appliance. | |
| • Do not touch any electric switch; do not use any phone in your building. | |



LIGHTING INSTRUCTIONS:

WARNING: The gas valve has an interlock device which will not allow the pilot burner to be lit until the thermo-couple has cooled. Allow approximately 60 seconds for the thermocouple to cool.

When lighting and re-lighting, the gas knob cannot be turned from pilot to off unless the knob is depressed slightly.

- Stop! Read the above safety information on this label.
- Turn off all electric power to the appliance.
- Turn the gas knob clockwise  to off.
- Wait five (5) minutes to clear out any gas. If you smell gas including near the floor. Stop! Follow "B" in the above safety information on this label. If you don't smell gas go the next step.
- Turn gas knob counter-clockwise  to pilot.
- Depress slightly and hold gas knob while lighting the pilot with the push button igniter. Keep knob depressed for one minute, then release. If pilot does not continue to burn, repeat steps 3 through 5.
- With pilot lit, depress and turn gas knob counter-clockwise  to on.
- If equipped with remote on-off switch / thermostat, main burner may not come on when you turn valve to on. Remote switch must be in the on position to ignite burner.
- Turn on all electric power to the appliance.

TO TURN OFF GAS

- Turn off all electric power to the appliance if service is to be performed.
- Push in gas control knob slightly and turn clockwise  to off. Do not force.

TURN THE CONTROL VALVE TO THE OFF POSITION WHEN HEATER IS NOT IN USE.

10.0 adjustment

10.1 pilot burner adjustment

Adjust the pilot screw to provide properly sized flame. Turn in a clockwise direction to reduce the gas flow.

Check Pressure Readings:

Inlet pressure can be checked by turning screw A counter-clockwise 2 or 3 times, and then placing the pressure gauge tubing over the test point. The gauge should read as described on the chart below. Check pressure with the main burner operating on "HI".

Outlet pressure can be checked the same as above using screw B. The gauge should read as described on the chart below. Check pressure with the main burner operating on "HI".

After turning screw A counter-clockwise 2 or 3 times, and then placing the pressure gauge tubing over the test point. The gauge should read as described on the chart below. Check pressure with the main burner operating on "HI".

AFTER TAKING PRESSURE READINGS, BE SURE TO TURN NOT OVER SCREWS-TORQUE CLOCKWISE. FIRMLY TO RESEAL. DO NOT OVERTORQUE.

Leak test with a soap and water solution.

Leak test with a soap and water solution.

Prior to pilot adjustment, ensure that the pilot assembly has not been painted. If overspray or painting of the pilot assembly has occurred remove the paint from the pilot

assembly, or replace. Fine emery cloth or a synthetic scrub pad (such as Scotch-Brite™) can be used to remove

the paint from the pilot hood, electrode and flame sensor.

*Maximum inlet pressure not to exceed 13".

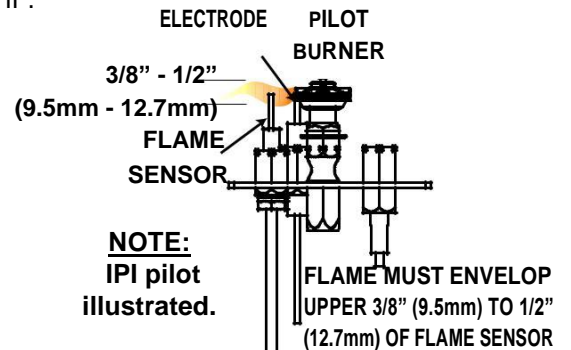

Pressure	Natural Gas (inches)	Natural Gas (millibars)	Propane (inches)	Propane (millibars)
Inlet	*13" (MIN. 4.5")	17.4mb (MIN. 11.2mb)	13" (MIN. 11")	32.4mb (MIN. 27.4mb)
Outlet	3.5"	8.7mb	10"	24.9mb

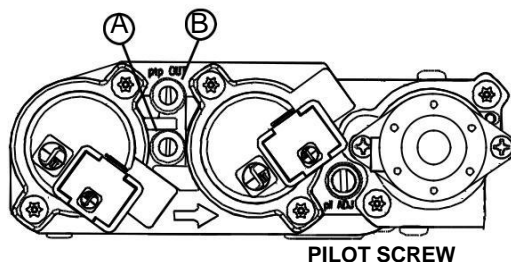

ELECTRONIC

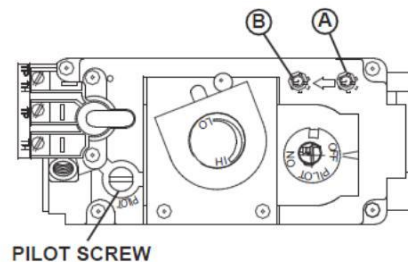

MILLIVOLT

10.2 venturi adjustment

This appliance has an air shutter that has been factory set open according to the chart below:

Regardless of venturi orientation, closing the air shutter will cause a more yellow flame, but can lead to carbonization. Opening the air shutter will cause a more blue flame, but can cause flame lifting from the burner ports. The flame may not appear yellow immediately; allow 15 to 30 minutes for the final flame colour to be established.

AIR SHUTTER ADJUSTMENT MUST ONLY BE DONE BY A QUALIFIED INSTALLER!

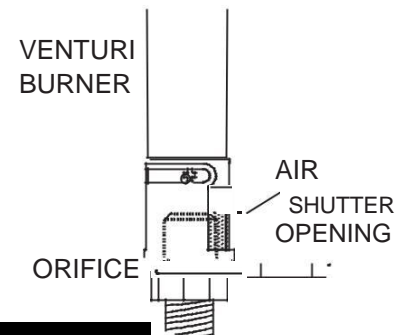

VENTURI ADJUSTMENT CHART				
CB36		CX36-1		
FUEL	TOP	REAR	TOP	REAR
NG	1/16" (1.5mm)	1/16" (1.5mm)	1/16" (1.5mm)	1/8" (3.2mm)
P	1/4" (6.3mm)	3/8" (9.5mm)	1/4" (6.3mm)	3/8" (9.5mm)

10.3 flame characteristics

It's important to periodically perform a visual check of the pilot and burner flames. Compare them to the illustrations provided. If any flame appears abnormal call a service person.

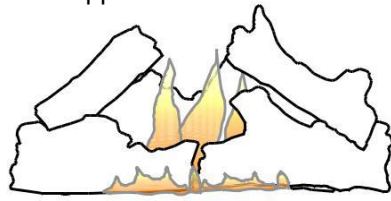

CB36

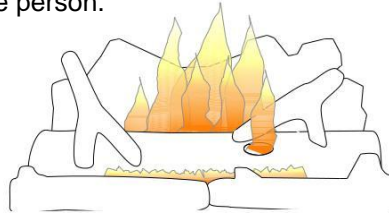

CX36-1

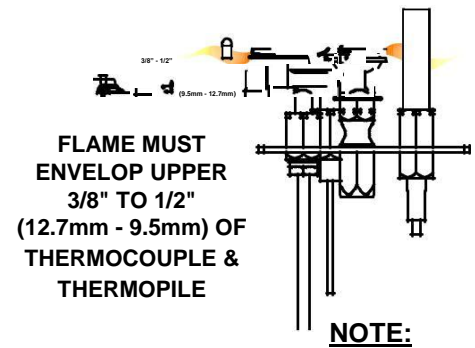

FLAME MUST ENVELOPE UPPER 3/8" TO 1/2" (12.7mm - 9.5mm) OF THERMOCOUPLE & THERMOPILE

IPI pilot illustrated.

NOTE:

10.4 optional anti-condensation switch (models CB36NTRE/CB36PTRE/CX36NTRE-1 & CX36PTRE-1 only)

This appliance has the option to change from an electronic intermittent pilot ignition (IPI) to a standing pilot for colder climates. The anti condensation switch (ACS) (standing pilot) is located in the center of the control panel.

If installed with the blue wire facing up, flipping the switch UP turns on the standing pilot and flipping the switch DOWN turns on the intermittent pilot ignition. If installed with the white wire facing up, the opposite is true.

Turning the ACS on will allow the pilot flame to burn continuously. This mode will minimize the condensation which forms on the inside of the glass when the main burner is first turned on. It will also help the fireplace and vent system stabilize faster during colder winter months.

During the warmer winter and summer months, the ACS can be turned off to minimize fuel consumption.

11.0 maintenance

MAINTENANCE!

EN

This appliance and its venting system should be inspected before use and at least annually by a qualified service person. The following suggested checks should be performed by a qualified technician. The appliance area must be kept clear and free of combustible materials, gasoline or other flammable vapors and liquids. The flow of combustion and ventilation air must not be obstructed.

CAUTION: Label all wires prior to disconnection when servicing controls. Wiring errors can cause improper and dangerous operation. Verify proper operation after servicing.

- A. In order to properly clean the burner and pilot assembly, remove the logs, rocks and/or glass to expose both assemblies.
- B. Keep the control compartment, media, burner, air shutter opening and the area surrounding the logs clean by vacuuming or brushing, at least once a year.
- C. Check to see that all burner ports are burning. Clean out any of the ports which may not be burning or are not burning properly.
- D. Check to see that the pilot flame is large enough to engulf the flame sensor and/or thermocouple / thermopile as well as reaches the burner.
- E. Replace the cleaned logs, rocks or glass. Failure to properly position the media may cause carbon which can be distributed inside of firebox and on exterior surfaces surrounding vent termination.
- F. Check to see that the main burner ignites completely on all openings when turned on. A 5 to 10 second total light-up period is satisfactory. Service as required.
- G. Check that the gasketing on the sides, top and bottom of the door is not broken or missing. Replace if necessary.
- H. If for any reason the vent air intake system is disassembled, re-install and re-seal per the instructions provided for the initial installation.
- I. Cleaning the safety barrier may be necessary due to excessive lint / dust from carpeting, pets, etc. simply vacuum using the brush attachment.
- J. Ensure the relief system performs effectively. Check that the gasket is not worn or damaged. Replace if necessary.

11.1 annual maintenance

! WARNING

THE FIREBOX BECOMES VERY HOT DURING OPERATION. LET THE APPLIANCE COOL COMPLETELY OR WEAR HEAT RESISTANT GLOVES BEFORE CONDUCTING SERVICE.

NEVER VACUUM HOT EMBERS.

DO NOT PAINT THE PILOT ASSEMBLY.

This appliance will require maintenance which should be planned on an annual basis.

Service should include cleaning, battery replacement, venting inspection and inspection of the burner, media and firebox. Refer to the door removal section and remove the door as instructed.

Carefully remove media if necessary (logs, glass, brick panels etc).

Using a vacuum with a soft brush attachment, gently remove any dirt, debris or carbon build up from the logs, firebox and burner. For glass media, follow the installation instructions for pre-cleaning.

Also gently remove any build-up on the pilot assembly including, if equipped; thermopile, thermocouple, flame sensor and igniter. **NOTE: Clean flame sensor using a fine emery cloth or a synthetic scrub pad (such as Scotch-Brite™) to remove any oxides. Clean the pilot assembly using a vacuum with a soft brush attachment. It is important that the pilot assembly is not painted.**

Inspect all accessible gaskets and replace as required.

Access the blower, if equipped and clean using a soft brush and vacuum.

Re-assemble the various components in reverse order.

Inspect the relief system. The appliance relieves through the main glass door or through the flaps on the firebox top. Ensure they open freely, and close sealed.

Check the gas control valve pilot and Hi / Lo knobs move freely (if equipped) – replace if any stiffness in movement is experienced.

Check for gas leaks on all gas connections up and downstream from the gas valve including the pilot tube connections.

11.2 door glass replacement

! WARNING

DO NOT USE SUBSTITUTE MATERIALS.

GLASS MAY BE HOT, DO NOT TOUCH GLASS UNTIL COOLED.

CARE MUST BE TAKEN WHEN REMOVING AND DISPOSING OF ANY BROKEN DOOR GLASS OR DAMAGED COMPONENTS. BE SURE TO VACUUM UP ANY BROKEN GLASS FROM INSIDE THE APPLIANCE BEFORE OPERATION.

DO NOT STRIKE, SLAM OR SCRATCH GLASS. DO NOT OPERATE APPLIANCE WITH GLASS REMOVED, CRACKED, BROKEN OR SCRATCHED.

Replacement glass/frame assembly shall be replaced as a complete unit as supplied by the appliance manufacturer.

11.3 care of glass

DO NOT CLEAN GLASS WHEN HOT! DO NOT USE ABRASIVE CLEANERS TO CLEAN GLASS.

Buff lightly with a clean dry soft cloth. Clean both sides of the glass after the first 10 hours of operation with a recommended fire replace glass cleaner. Do not use an ammonia-based fire replace glass cleaner. Thereafter clean as required. If the glass is not kept clean permanent discoloration and / or blemishes may result.



CB36:

This appliance is factory equipped with 4mm tempered glass. Use only replacement parts available from your appliance manufacturer. **DO NOT SUBSTITUTE MATERIALS.**

CX36-1:

This appliance is factory equipped with 5mm ceramic glass. Use only replacement parts as supplied by the appliance manufacturer. **DO NOT SUBSTITUTE MATERIALS.**

12.0 replacements

! WARNING
FAILURE TO POSITION THE PARTS IN ACCORDANCE WITH THIS MANUAL OR FAILURE TO USE ONLY PARTS SPECIFICALLY APPROVED WITH THIS APPLIANCE MAY RESULT IN PROPERTY DAMAGE OR PERSONAL INJURY.
** THIS IS A FAST ACTING THERMOCOUPLE. IT IS AN INTEGRAL SAFETY COMPONENT. REPLACE ONLY WITH A FAST ACTING THERMOCOUPLE SUPPLIED BY WOLF STEEL LTD.

Contact your dealer for questions concerning prices and policies on replacement parts. Normally all parts can be ordered through your Authorized dealer / distributor.

FOR WARRANTY REPLACEMENT PARTS, A PHOTOCOPY OF THE ORIGINAL INVOICE WILL BE REQUIRED TO HONOUR THE CLAIM.

When ordering replacement parts always give the following information:

Model & Serial Number of appliance

Installation date of appliance

Part number

Description of part

Finish

PARTS, PART NUMBERS AND AVAILABILITY ARE SUBJECT TO CHANGE WITHOUT NOTICE.

PARTS IDENTIFIED AS STOCKED WILL BE DELIVERED WITHIN 2 TO 5 BUSINESS DAYS FOR MOST DELIVERY DESTINATIONS.

PARTS NOT IDENTIFIED AS STOCKED WILL BE DELIVERED WITHIN A 2 TO 4 WEEK PERIOD.

PARTS IDENTIFIED AS 'SO' ARE SPECIAL ORDER AND CAN TAKE UP TO 90 DAYS FOR DELIVERY.

12.1 CB36 overview

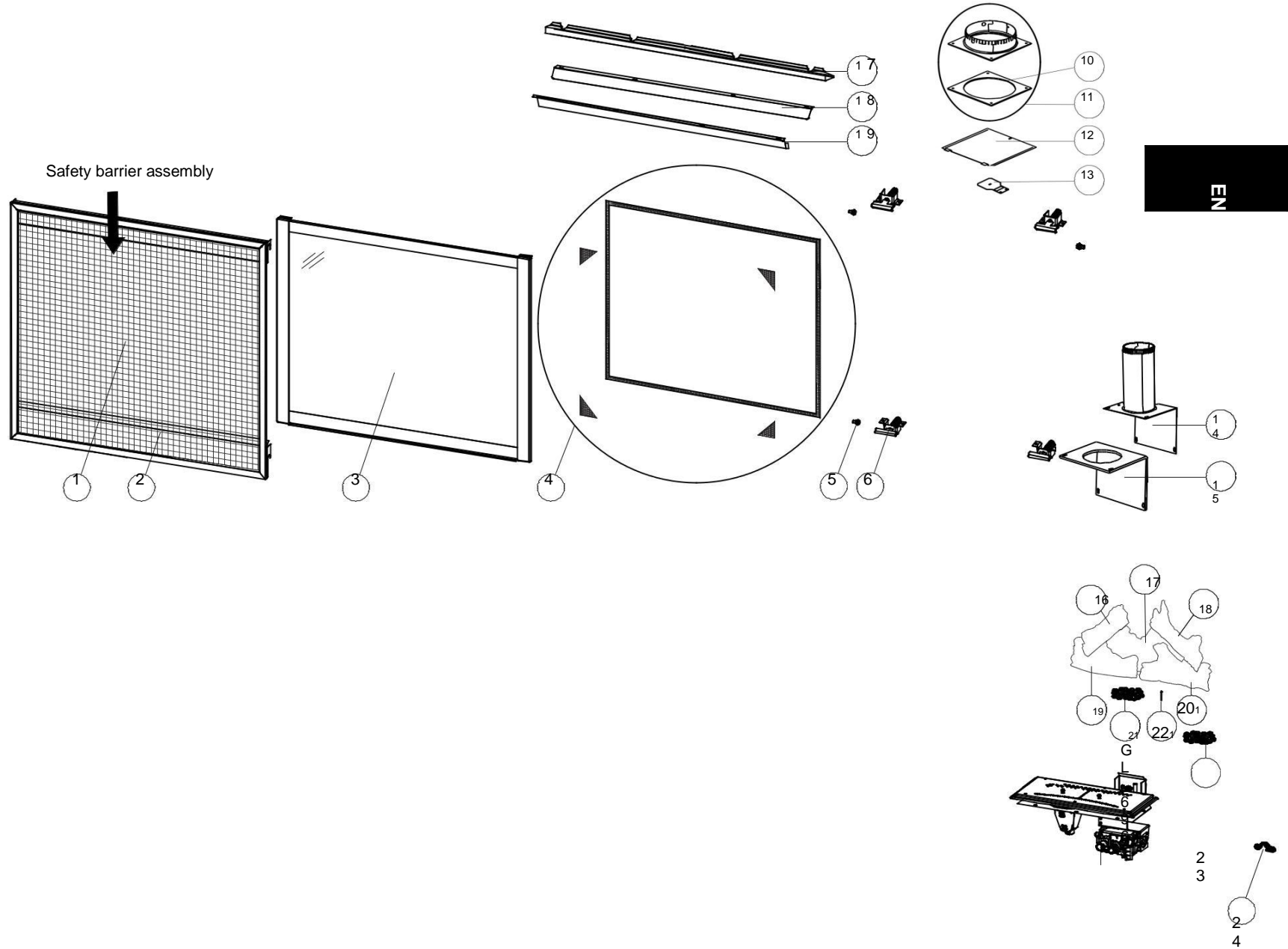

Items may not appear exactly as illustrated.

"valve train assembly"

Ref. No.	Part Number	Description	Stocked
1	W565-0209-SER	Safety Screen	
2	W010-3072-SER	Safety Barrier Assembly	
3	W010-3068-SER	Complete Door Assembly	Yes
4	W562-0068	Door Gasket Assembly	Yes
5	W570-0135	Shoulder Screws	Yes
6	W010-3554	Door Latch	
7	W335-0063-SER	Hood	
8	W715-1040-SER	Top Finishing Trim	
9	W018-0158-SER	Front Baffle	
10	W290-0054	7" Flange Gasket	Yes
11	W010-3489-SER	7" Air Collar Assembly	
12	W500-0837	Vent Cover Plate	

Ref. No.	Part Number	Description	Stocked
13	RP4	4" Restrictor Plate	Yes
14	W010-3490-SER	Exhaust Collar Assembly	
15	W290-0282	Exhaust Bracket Gasket	
16	W135-0546	Left Crossover Log (GL-696)	Yes
17	W135-0643	Rear Log (GL-696)	Yes
18	W135-0589	Right Crossover Log (GL-696)	Yes
19	W135-0644	Left Front Log (GL-696)	Yes
20	W135-0645	Right Front Log (GL-696)	Yes
21	W361-0016	Glowing Embers (GL-696)	Yes
22	W485-0042	Log Locating Pin (X2)	Yes
23	W550-0001	Charcoal Embers	Yes
24	W385--04302010	NapoleonContinentalLogo	Yes

09.13.16

12.2 CB36 millivolt valve assembly

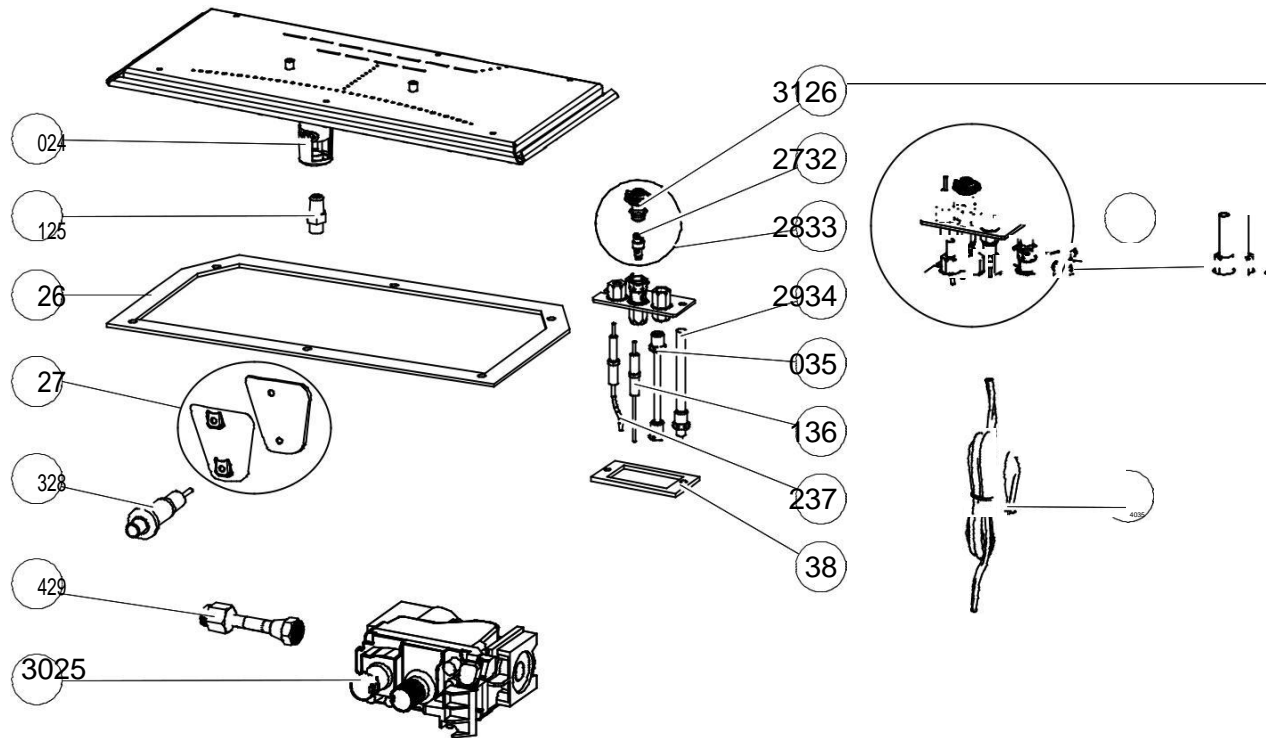

Items may not appear exactly as illustrated.

Ref. No.	Part Number	Description	Stocked
24	W100-0190-SER	Burner Assembly	Yes
25	W456-0047	Burner Orifice #47 (NG)	Yes
25	W456-0056	Burner Orifice #56 (P)	Yes
26	W290-0248	Valve Train Gasket	
27	W500-0276-SER	Venturi Cover Assembly	
28	W357-0001	Push Button Ignitor	Yes
29	W432-0078	Manifold Flex Pipe	Yes
30	W725-0025	Valve (NG)	Yes
30	W725-0026	Valve (P)	Yes
31	W335-0039	Pilot Hood	Yes
32	W455-0070	Pilot Orifice #62 (NG)	Yes

Ref. No.	Part Number	Description	Stocked
32	W455-0068	Pilot Orifice #35 (P)	Yes
33	W010-0801	Pilot (NG)	Yes
33	W010-0800	Pilot (P)	Yes
34	W680-0004	Thermopile	Yes
35	W720-0062	Pilot Tube (w/ Fittings)	Yes
36	W240-0006-SER	Electrode (w/ Wire)	Yes
37	W680-0005	Thermocouple **	Yes
38	W290-0029	Pilot Gasket	Yes
39	W010-0798	Complete Pilot Assembly (NG)	Yes
39	W010-0799	Complete Pilot Assembly (P)	Yes
40	W750-0112	Wire Switch	

**** THIS IS A FAST ACTING THERMOCOUPLE. IT IS AN INTEGRAL SAFETY COMPONENT. REPLACE ONLY WITH A FAST ACTING THERMOCOUPLE SUPPLIED BY WOLF STEEL LTD.**



12.3 CB36 electronic valve assembly

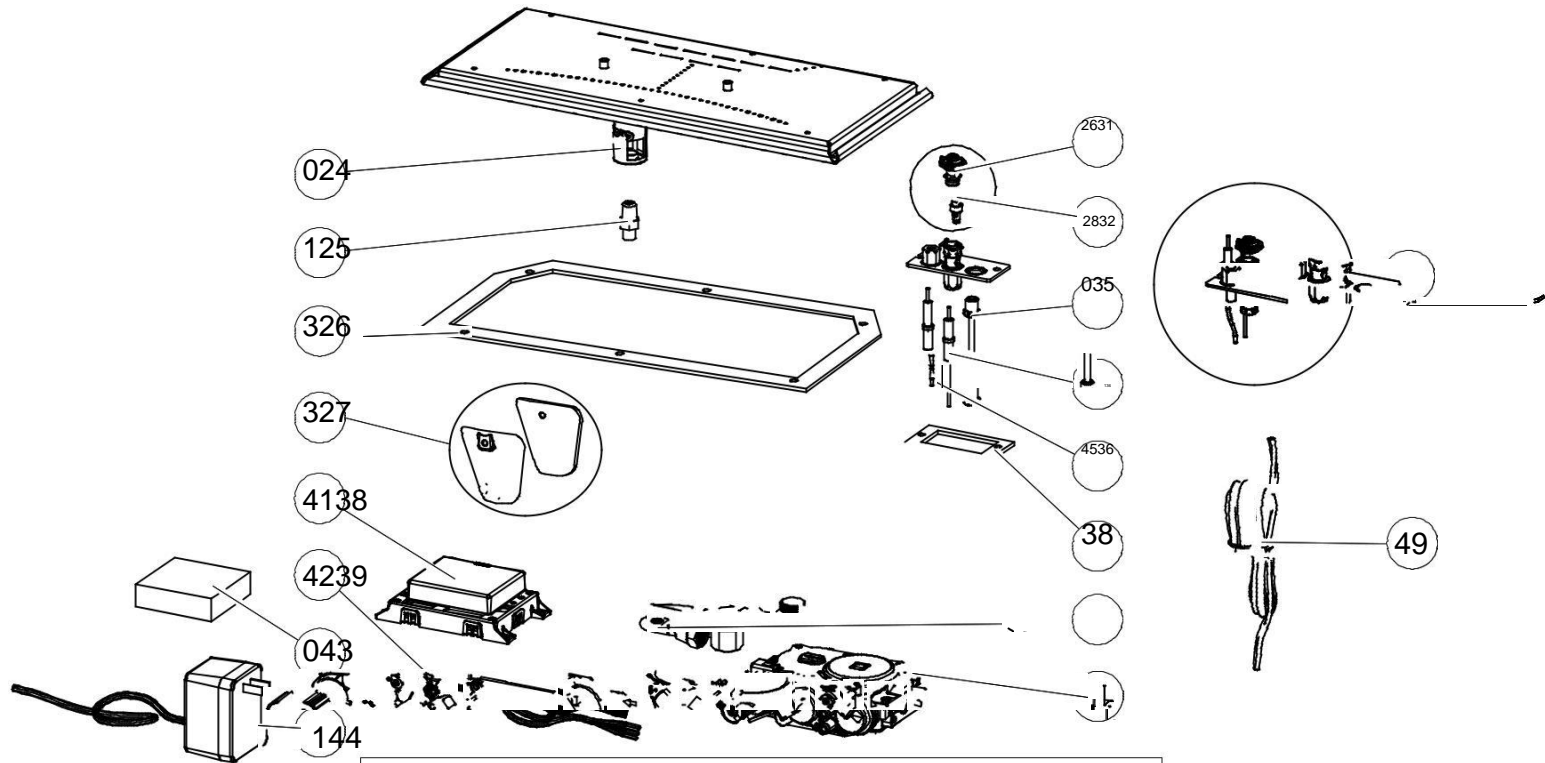

Items may not appear exactly as illustrated.

Ref. No.	Part Number	Description	Stocked
24	W100-0190-SER	Burner Assembly	Yes
25	W456-0047	Burner Orifice #47 (NG)	Yes
25	W456-0056	Burner Orifice #56 (P)	Yes
26	W290-0248	Valve Train Gasket	
27	W500-0276-SER	Venturi Cover Assembly	
31	W335-0039	Pilot Hood	Yes
32	W455-0070	Pilot Orifice #62 (NG)	Yes
32	W455-0068	Pilot Orifice #35 (P)	Yes
35	W720-0062	Pilot Tube (w/ Fittings)	Yes
36	W240-0013	Electrode (w/ Wire)	Yes
38	W290-0029	Pilot Gasket	Yes

Ref. No.	Part Number	Description	Stocked
45	W245-0025	Thermosensor	Yes
41	W190-0104	Control Module	Yes
42	W010-1986	Wire Harness (CSA)	Yes
43	W350-0702	Battery Back-Up	Yes
44	W707-0010	Transformer	Yes
46	W432-0078	Manifold Flex Pipe	Yes
47	W725-0062	886 Proflame Valve (NG)	Yes
47	W725-0063	886 Proflame Valve (P)	Yes
48	W010-2763	Pilot Assembly (NG)	Yes
48	W010-2808	Pilot Assembly (P)	Yes
49	W750-0270	Wire Switch	

12.4 CX36-1 overview

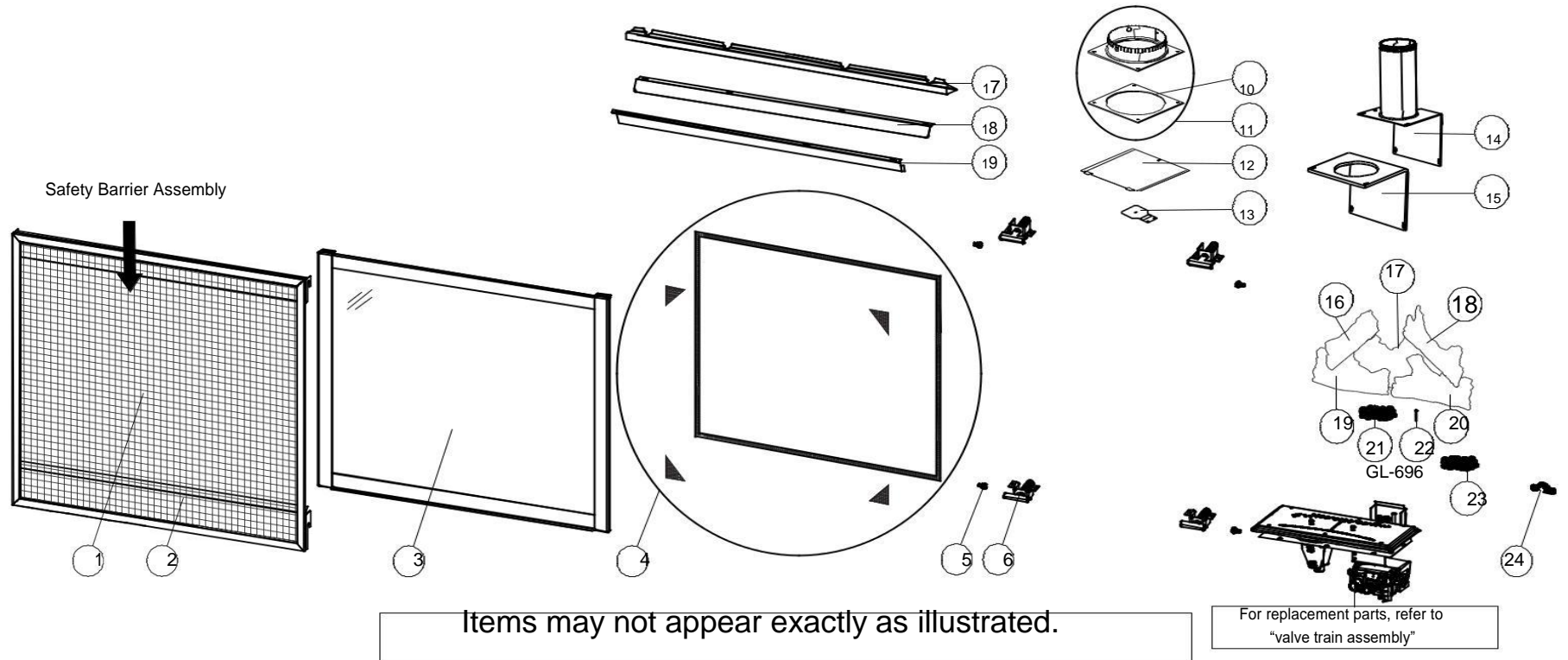

Ref. No.	Part Number	Description	Stocked
1	W565-0242-SER	Safety Screen	Yes
2	W010-4006-SER	Safety Barrier Assembly	Yes
3	W010-3402-SER	Complete Door Assembly	Yes
4	W562-0062	Door Gasket Assembly	Yes
5	W570-0135	Shoulder Screws	Yes
6	W010-3554	Door Latch	
7	W715-1040-SER	Top Finishing Trim	
8	W335-0063-SER	Hood	
9	W018-0158-SER	Front Baffle	
10	W290-0054	7" Flange Gasket	Yes
11	W010-3489-SER	7" Air Collar Assembly (C/W Gasket)	
12	W500-0837	Vent Cover Plate	

Ref. No.	Part Number	Description	Stocked
13	RP4	4" Restrictor Plate	Yes
14	W010-3490-SER	Exhaust Collar Assembly	
15	W290-0282	Exhaust Bracket Gasket	
16	W135-0546	Left Crossover Log (GL-696)	Yes
17	W135-0643	Rear Log (GL-696)	Yes
18	W135-0589	Right Crossover Log (GL-696)	Yes
19	W135-0644	Left Front Log (GL-696)	Yes
20	W135-0645	Right Front Log (GL-696)	Yes
21	W361-0016	Glowing Embers (GL-696)	Yes
22	W485-0042	Log Locating Pins (x2)	Yes
23	W485-0051	Charcoal Embers	Yes
24	W385-0430	Continental Logo	Yes



12.5 CX36-1 millivolt valve assembly

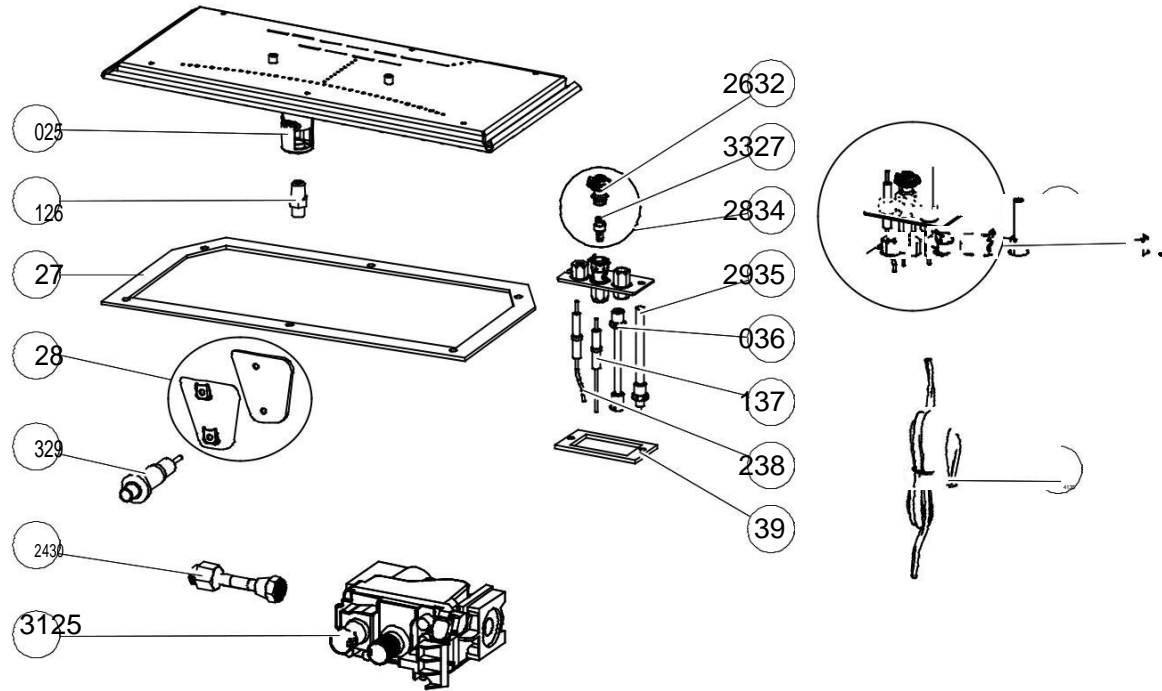

Items may not appear exactly as illustrated.

Ref. No.	Part Number	Description	Stocked	Ref. No.	Part Number	Description	Stocked
25	W100-0191-SER	Burner Assembly	Yes	33	W455-0068	Pilot Orifice #35 (P)	Yes
26	W456-0042	Burner Orifice #42 (NG)	Yes	34	W010-0801	Pilot (NG)	Yes
26	W456-0053	Burner Orifice #53 (P)	Yes	34	W010-0800	Pilot (P)	Yes
27	W290-0248	Valve Train Gasket		35	W680-0004	Thermopile	Yes
28	W500-0276-SER	Venturi Cover Assembly		36	W720-0062	Pilot Tube (w/ Fittings)	Yes
29	W357-0001	Push Button Ignitor	Yes	37	W240-0006-SER	Electrode (w/ Wire)	Yes
30	W432-0078	Manifold Flex Pipe	Yes	38	W680-0005	Thermocouple **	Yes
31	W725-0025	Valve (NG)	Yes	39	W290-0029	Pilot Gasket	Yes
31	W725-0026	Valve (P)	Yes	40	W010-0798	Complete Pilot Assembly (NG)	Yes
32	W335-0039	Pilot Hood	Yes	40	W010-0799	Complete Pilot Assembly (P)	Yes
33	W455-0070	Pilot Orifice #62 (NG)	Yes	41	W750-0112	Wire Switch	

**** THIS IS A FAST ACTING THERMOCOUPLE. IT IS AN INTEGRAL SAFETY COMPONENT. REPLACE ONLY WITH A FAST ACTING THERMOCOUPLE SUPPLIED BY WOLF STEEL LTD.**

12.6 CX36-1 electronic valve assembly

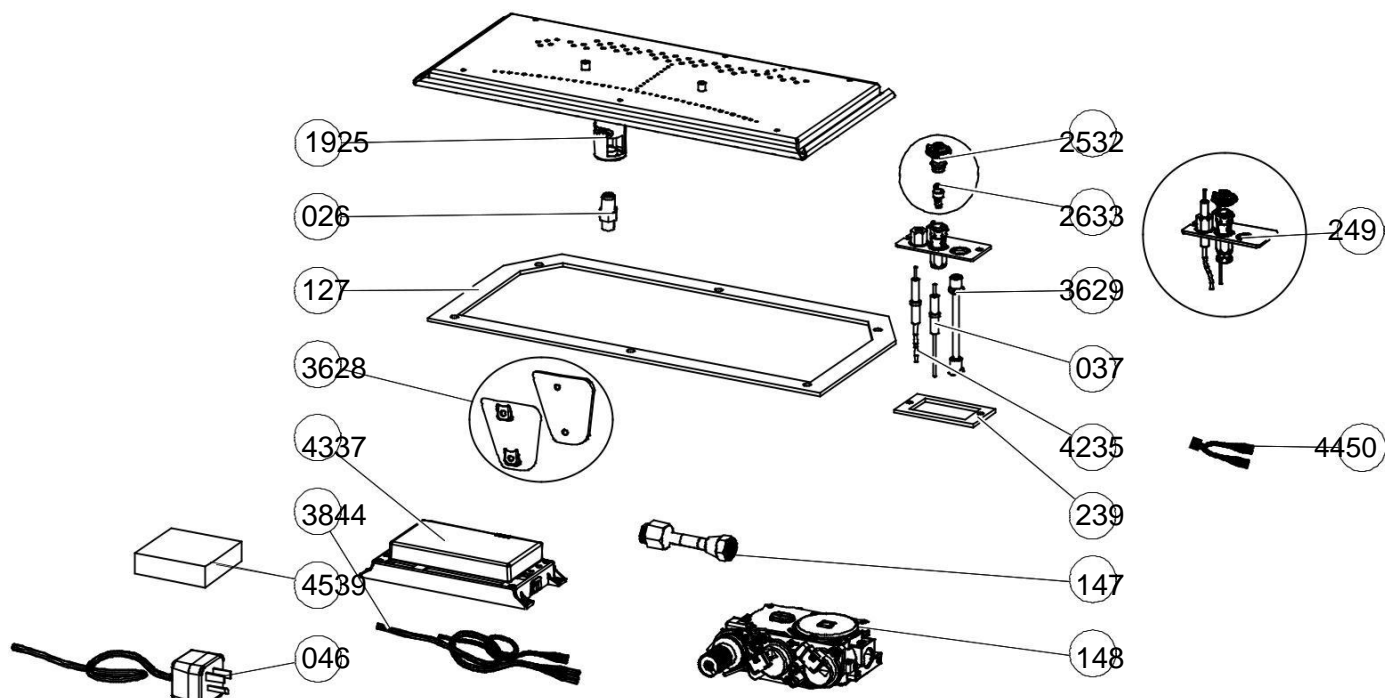

Items may not appear exactly as illustrated.

Ref. No.	Part Number	Description	Stocked	Ref. No.	Part Number	Description	Stocked
25	W100-0191-SER	Burner Assembly	Yes	42	W245-0025	Thermosensor	Yes
26	W456-0042	Burner Orifice #42 (NG)	Yes	43	W190-0113	Control Module	Yes
26	W456-0053	Burner Orifice #53 (P)	Yes	44	W750-0267	Wire Harness (Control)	Yes
27	W290-0248	Valve Train Gasket		45	W350-0702	Battery Back-Up	Yes
28	W500-0276-SER	Venturi Cover Assembly		46	W750-0294	Power Cord	
32	W335-0039	Pilot Hood	Yes	47	W432-0078	Manifold Flex Pipe	Yes
33	W455-0070	Pilot Orifice #62 (NG)	Yes	48	W725-0062	Valve (NG)	Yes
33	W455-0068	Pilot Orifice #35 (P)	Yes	48	W725-0063	Valve (P)	Yes
36	W720-0062	Pilot Tube (w/ Fittings)	Yes	49	W010-2763	Pilot Assembly (NG)	Yes
37	W240-0013	Electrode (w/ Wire)	Yes	49	W010-2808	Pilot Assembly (P)	Yes
39	W290-0029	Pilot Gasket	Yes	50	W175-0633	6" Connector	



13.0

CB36 accessories

W415-1679 / D / 03.09.18

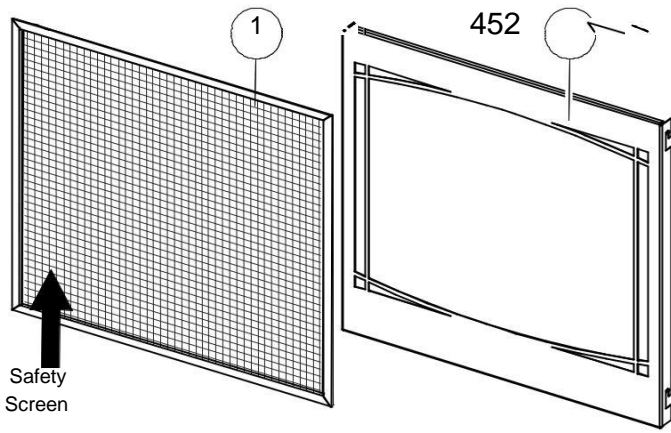

Z35F

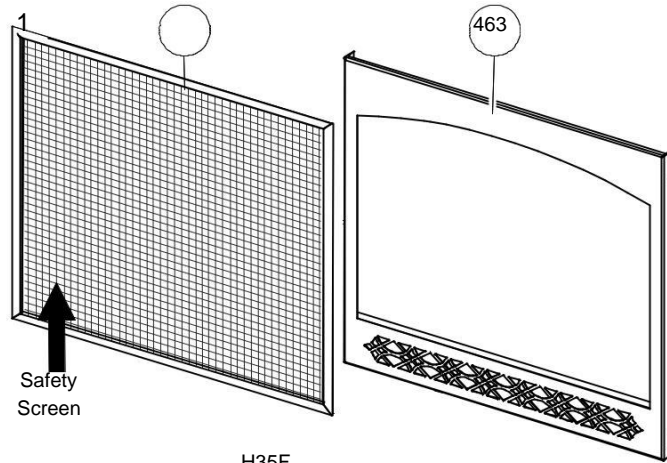

H35F

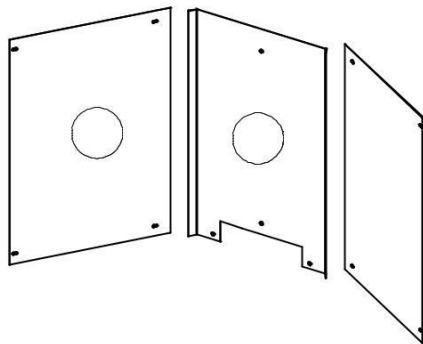
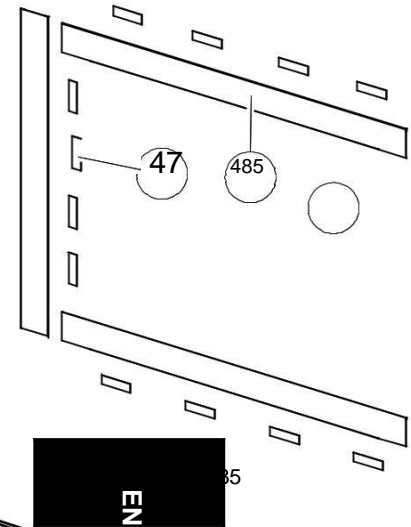

507

518

PRPB36

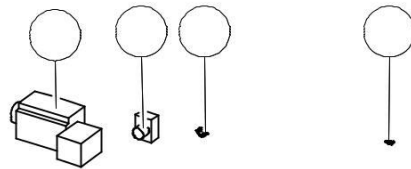

529

5310

5411

5512

AUB

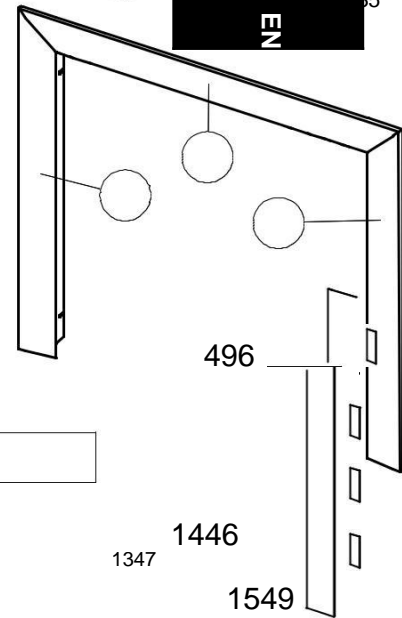

1347

1446

1549

BT36K

Items may not appear exactly as illustrated.

Ref. No.	Part Number	Description	Stocked
1	W565-0209-SER	Safety Screen (Z35F & H35F)	
2	W010-3275	Zen Front Assembly (Z35F)	
3	W010-3124	Heritage Front Assembly (H35F)	
4	W430-0003	Magnet (X16) (TK35)	
5	W715-0953	Top / Bottom Trim (X2) (TK35)	
6	W715-0952	Side Trim (X2) (TK35)	
7	W475-1012	Side Porcelain Panel (X2) (PRPB36)	
8	W475-1013	Rear Porcelain Panel (PRPB36)	

Ref. No.	Part Number	Description	Stocked
9	W062-0059	Blower (AUB)	
10	KB-35	Variable Speed Switch	Yes
11	W690-0002	Thermodisc	Yes
12	ACS-SIT	Anti-Condensation Switch (ACS)	Yes
13	W715-1069-SER	Left Side Bevelled Trim (BT36K)	
14	W715-1068-SER	Top Bevelled Trim (BT36K)	
15	W715-1070-SER	Right Side Bevelled Trim (BT36K)	

05.19.16 / B

14.0CX36-1 accessories

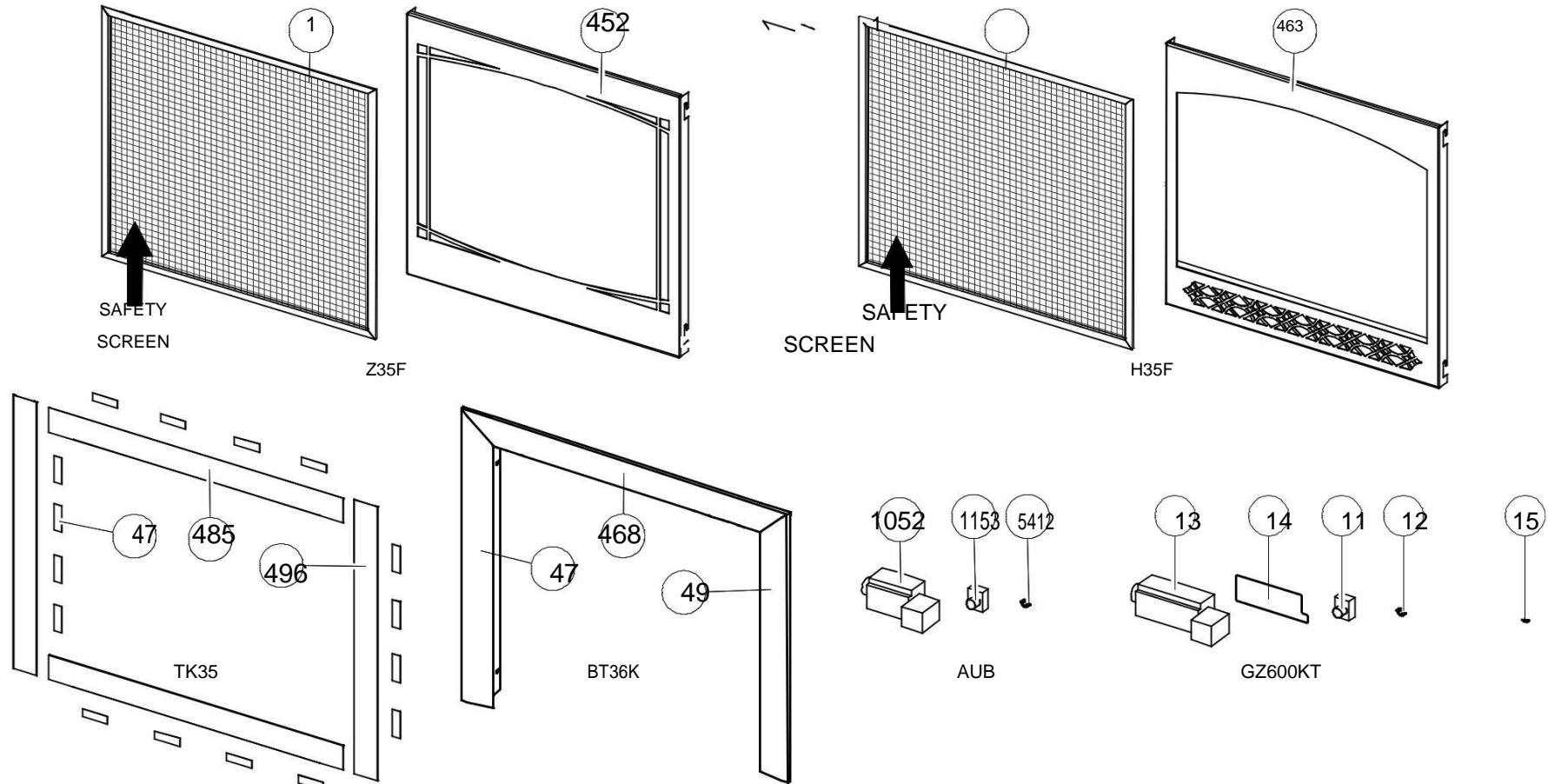

Items may not appear exactly as illustrated.

Ref. No.	Part Number	Description	Stocked
1	W565-0242-SER	Safety Screen (Z35F & H35F)	Yes
2	W010-3275	Zen Front Assembly (Z35F)	
3	W010-3124	Heritage Front Assembly (H35F)	
4	W430-0003	Magnet (TK35)	
5	W715-0953	Top / Bottom Trim (TK35)	
6	W715-0952	Side Trim (TK35)	
7	W715-1069-SER	Left Side Bevelled Trim (BT36K)	
8	W715-1068-SER	Top Bevelled Trim (BT36K)	

Ref. No.	Part Number	Description	Stocked
9	W715-1070-SER	Right Side Bevelled Trim (BT36K)	
10	W062-0059	Blower Assembly (AUB)	
11	KB-35	Variable Speed Switch Assembly	Yes
12	W690-0002	Thermodisc	Yes
13	W062-0051	Blower Assembly (GZ600KT)	Yes
14	W290-0345	Blower Gasket (GZ600KT)	
15	ACS-SIT	Anti-Condensation Switch (ACS)	Yes

W415-1679 / D / 03.09.18

W415-1679 / D / 03.09.18

C
X
3
6
-1

a
c
c
e
s
s
o
r
i
e
s

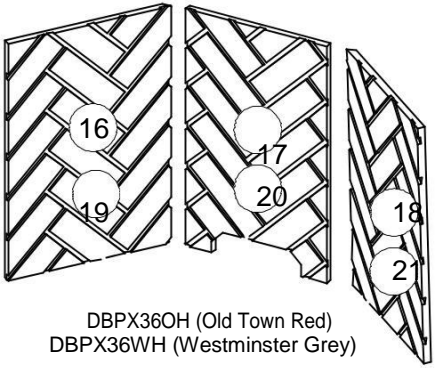

DBPX36OH (Old Town Red)
DBPX36WH (Westminster Grey)

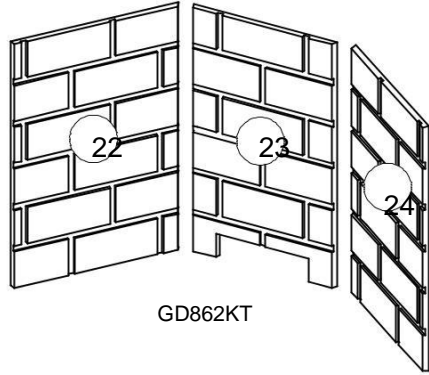

GD862KT

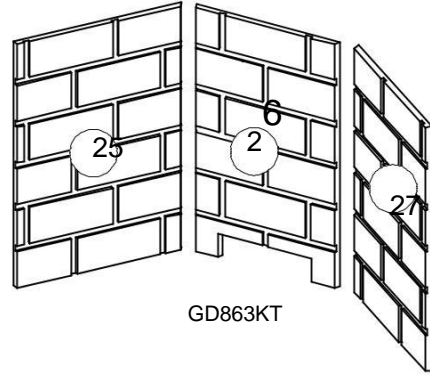

GD863KT

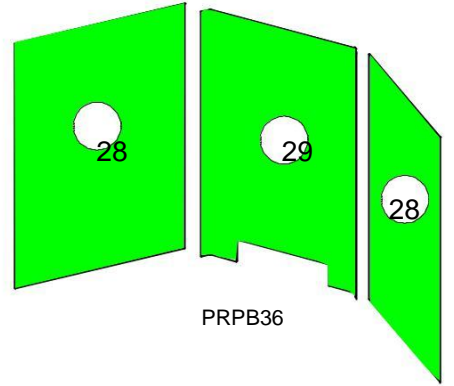

PRPB36

Items may not appear exactly as illustrated.

Ref. No.	Part Number	Description	Stocked
16	W475-1546	Left Side Herringbone Panel, Old Town Red (DBPX36OH)	
17	W475-1547	Rear Herringbone Panel, Old Town Red (DBPX36OH)	
18	W475-1545	Right Side Herringbone Panel, Old Town Red (DBPX36OH)	
19	W475-1552	Left Side Herringbone Panel, Westminster Grey (DBPX36WH)	
20	W475-1553	Rear Herringbone Panel, Westminster Grey (DBPX36WH)	
21	W475-1551	Right Side Herringbone Panel, Westminster (DBPX36WH)	
22	W475-0992	Left Side Sandstone Brick Panel (GD862KT)	
23	W475-0991	Rear Sandstone Brick Panel (GD862KT)	
24	W475-1005	Right Side Sandstone Brick Panel (GD862KT)	
25	W475-0997	Left Side Newport Brick Panel (GD863KT)	
26	W475-0996	Rear Newport Brick Panel (GD863KT)	
27	W475-1006	Right Side Newport Brick Panel (GD863KT)	
28	W475-1012-BK2GL	Side Porcelain Panels (X2) (PRPB36)	
29	W475-1013-BK2GL	Rear Porcelain Panel (PRPB36)	

15.0 troubleshooting (electronic)

! WARNING

EN

ALWAYS LIGHT THE PILOT WHETHER FOR THE FIRST TIME OR IF THE GAS SUPPLY HAS RUN OUT, WITH THE GLASS DOOR OPEN OR REMOVED.

TURN OFF THE GAS AND ELECTRICAL POWER BEFORE SERVICING THE APPLIANCE.

APPLIANCE MAY BE HOT, DO NOT SERVICE UNTIL APPLIANCE HAS COOLED.

DO NOT USE ABRASIVE CLEANERS.

SYMPTOM	PROBLEM	TEST SOLUTION
Pilot will not light. Makes noise with no spark at pilot burner.	Wiring.	- Verify the wire for the sensor and the wire for the ignitor are connected to the correct terminals (not reversed) on the module. NOTE: Sensor has 3/16" (4.8mm) connection and ignitor has 1/8" (3.2mm) connection.
	Loose connection.	- Verify no loose connections, electrical shorts in the wiring or ground out to any metal object.
	Module.	- Turn the ON/OFF switch to the "OFF" position. Remove the ignitor wire from the module. Place the ON/OFF switch to the "ON" position. Hold a grounded wire about 3/16" (4.8mm) away from the ignitor (spark) terminal on the module. If no spark the ignitor terminal module must be replaced. If there is a spark the ignitor terminal is fine. Inspect pilot assembly for a shorted wire or cracked insulator around the electrode.
	Igniter Spark gap is incorrect.	- Spark gap of the ignitor to the pilot should be 1/8" (3.2mm).
	Transformer.	- Verify the transformer is installed and plugged into the module. Check voltage of the transformer under load at the spade connections on the module with the ON/OFF switch in the "ON" position. Acceptable readings of a good transformer are between 6.2 and 7.0 volts A.C.
	Battery backup (if power is off)	- Check batteries.
	A shorted or loose Connection.	- Remove and reinstall the wiring harness that plugs into the module. Remove and verify continuity of each wire in wiring harness.
	Improper switch wiring.	- Troubleshoot the system with the simplest ON/OFF switch.
	Module is not grounded.	- Verify the valve and pilot assemblies are properly grounded to the metal chassis of the appliance or log set.
	Pilot sparks but will not light.	Gas supply.
Out of propane gas.		- Fill the tank.
Carbon is being deposited on glass, logs, rocks, media or combustion chamber surfaces.	Air shutter has become blocked.	- Ensure air shutter opening is free of lint or other obstructions.
	Flame is impinging on the glass, logs, rocks, media or combustion chamber.	<ul style="list-style-type: none"> - Check that the glass, logs, rocks or media are correctly positioned. - Too much glass media around the burner can cause carbon deposits. - Open air shutter to increase the primary air. - Check the input rate: check the manifold pressure and orifice size as specified by the rating plate values. - Check that the door gasketing is not broken or missing and that the seal is tight. - Check that both vent liners are free of holes and well sealed at all joints. - Check that minimum rise per foot has been adhered to for any horizontal venting.

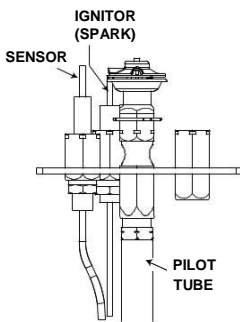

SYMPTOM	PROBLEM	TEST SOLUTION
Continues to spark and pilot lights, but main burner will not light.	Short or loose connection in sensor rod.	- Verify all connections. Verify the connections from the pilot assembly are tight; also verify these connections are not grounding out to any metal.
	Poor flame rectification or contaminated sensor rod.	- Verify the flame is engulfing the sensor rod. This will increase the flame rectification. Verify correct pilot orifice is installed and inlet gas specifications to manual. (Remember, the flame carries the rectification current, not the gas. If the flame lifts from pilot hood, the circuit is broken. A wrong orifice or too high of an inlet pressure can cause the pilot flame to lift.) The sensor rod may need cleaning.
	Poor grounding between pilot assembly and gas valve.	- Verify that the wire harness is firmly connected to module. Verify that the ceramic insulator around the sensor rod is not cracked, damaged, or loose. Verify the connection from the sensor rod to the sensor wire.
	Damaged pilot or dirty sensor rod.	- Clean sensor rod with a fine emery cloth or synthetic scrub pad to remove any contamination that may have accumulated on the sensor rod. Verify continuity with multimeter with ohms set at the lowest range.
Pilot lights Stops sparking / pilot remains lit but burner will not turn on.	Wiring / Connection.	- Inspect all wires, ensure good tight connections. Verify that all wiring is installed exactly as specified.
	Wiring harness.	- Inspect the wiring harness, and verify the harness is tightly connected to the module. Verify that all wires are connected in the right order. See "WIRING DIAGRAM" section.
Exhaust fumes smelled in room, headaches.	Appliance is spilling.	- Check all seals. - Check if exhaust is re-entering through an open door or window.
White / grey film forms.	Sulphur from fuel is being deposited on glass, logs or combustion chamber surfaces.	- Clean the glass, see "CARE OF GLASS" section - DO NOT CLEAN GLASS WHEN HOT. - If deposits are not cleaned off regularly, the glass may become permanently marked.
Flames are very aggressive.	Door is ajar.	- Tighten door clamps if applicable.
	Venting action is too great.	- Restrict vent exit with restrictor plate. See "RESTRICTING VENTS" section if applicable.
Main burner flame is a blue, lazy, transparent flame.	Blockage in vent.	- Remove blockage. In extreme conditions, ice buildup may occur on the terminal and should be removed. To minimize this from happening again, it is recommended that the vent lengths that pass through unheated spaces (attics, garages, crawl spaces) be wrapped with an insulated mylar sleeve. Prevent sleeve from sagging. Contact your local authorized dealer for more information.
	Compromised venting.	- Check venting system parameters (seal, length, rise, etc.).
Main burner goes out: pilot goes out.	Vent recirculation.	- Check joint seals and installation.

16.0 troubleshooting (millivolt)

! WARNING

EN

ALWAYS LIGHT THE PILOT WHETHER FOR THE FIRST TIME OR IF THE GAS SUPPLY HAS RUN OUT, WITH THE GLASS DOOR OPEN OR REMOVED.

TURN OFF THE GAS AND ELECTRICAL POWER BEFORE SERVICING THE APPLIANCE.

APPLIANCE MAY BE HOT, DO NOT SERVICE UNTIL APPLIANCE HAS COOLED.

DO NOT USE ABRASIVE CLEANERS.

SYMPTOM	PROBLEM	TEST SOLUTION
Main burner goes out; pilot stays on.	Pilot flame is not large enough or not engulfing the thermopile.	- Turn up the pilot flame. - Replace pilot assembly.
	Thermopile shorting.	- Clean thermopile connection to the valve. Reconnect. - Replace thermopile / valve.
	Remote wall switch wire is too long; too much resistance in the system.	- Shorten wire to correct length or wire gauge.
	Faulty thermostat or switch.	- Replace.
Main burner goes out; pilot goes out.	Refer to "MAIN BURNER GOES OUT; PILOT STAYS ON"	
	Vent is blocked	- Check for vent blockage.
	Vent is re-circulating	- Check joint seals and installation
	Flexible vent has become disconnected from appliance.	- Re-attach to appliance. - Cap was not replaced.
Pilot goes out when the gas knob is released. If equipped, the gas valve has an interlock device which will not allow the pilot burner to be lit until the thermocouple has cooled. Allow approximately 60 seconds for the thermocouple to cool.	System is not correctly purged	- Purge the gas line.
	Out of propane gas.	- Fill the tank.
	Pilot flame is not large enough.	- Turn up the pilot flame.
	Thermocouple shorting / faulty.	- Loosen and tighten thermocouple. - Clean thermocouple and valve connection. - Replace thermocouple. - Replace valve.
Pilot burning; no gas to main burner; gas knob is on 'HI'; wall switch / thermostat is on.	Faulty valve.	- Replace.
	Thermostat or switch is defective	- Connect a jumper wire across the wall switch terminals; if main burner lights, replace switch / thermostat.
	Wall switch wiring is defective.	- Disconnect the switch wires & connect a jumper wire across terminals 1 & 3; if the main burner lights, check the wires for defects and/or replace wires.
	Main burner orifice is plugged.	- Remove stoppage in orifice.
Pilot goes out while standing; Main burner is in 'OFF' position.	Faulty valve.	- Replace.
	Gas piping is undersized.	- Turn on all gas appliances and see if pilot flame flutters, diminishes or extinguishes, especially when main burner ignites. Monitor appliance supply working pressure. - Check if supply piping size is to code. Correct all undersized piping.
Main burner flame is a blue, lazy, transparent flame.	Blockage in vent.	- Remove blockage. In really cold conditions, ice buildup may occur on the terminal and should be removed as required. To minimize this from happening again, it is recommended that the vent lengths that pass through unheated spaces (attics, garages, crawl spaces) be wrapped with an insulated mylar sleeve. Prevent sleeve from sagging. Contact your local authorized dealer for more information.
Flames are very aggressive.	Door is ajar.	- Ensure the mechanical means of securing the door is providing a tight seal.
	Venting action is too great.	- Check to ensure venting is properly sealed. - If restriction is required see "RESTRICTING VERTICAL VENT" section.

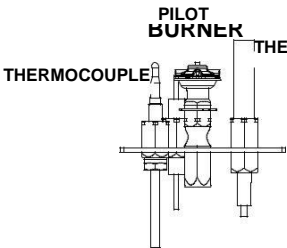
SYMPTOM	PROBLEM	TEST SOLUTION													
Pilot will not light. 	No spark at pilot burner.	<ul style="list-style-type: none"> - Check if pilot can be lit by a match. - Check that the wire is connected to the push button igniter. - Check if the push button igniter needs tightening. - Replace the wire if the wire insulation is broken or frayed. - Replace the electrode if the ceramic insulator is cracked or broken. - Replace the push button igniter 													
	Out of propane gas.	<ul style="list-style-type: none"> - Fill the tank. 													
	Spark gap is incorrect.	<ul style="list-style-type: none"> - Spark gap should be 0.150" (3.8mm) to 0.175" (4.5mm) from the electrode tip and the pilot burner. To ensure proper electrode location, tighten securing nut (finger tight plus 1/4 turn). 													
	No gas at the pilot burner.	<ul style="list-style-type: none"> - Check that the manual valve is turned on. - Check the pilot orifice for blockage. - Replace the valve. - Call the gas distributor. 													
Flames are consistently too large or too small. Carboning occurs.	Unit is over-fired or under-fired.	<ul style="list-style-type: none"> - Check pressure readings. - Inlet pressure can be checked by turning screw (A) counter-clockwise 2 or 3 turns and then placing pressure gauge tubing over the test point. Gauge should read as described on the chart below. Check with main burner is operating on 'HI'. - Outlet pressure can be checked the same as above using screw (B). Gauge should read as described on the chart below. Check that main burner is operating on 'HI'. - AFTER TAKING PRESSURE READINGS, BE SURE TO TURN SCREWS CLOCKWISE FIRMLY TO RESEAL. DO NOT OVER TORQUE. - Leak test with a soap and water solution. 													
		<table border="1"> <thead> <tr> <th>Pressure</th> <th>Natural Gas (inches)</th> <th>Natural Gas (millibars)</th> <th>Propane (inches)</th> <th>Propane (millibars)</th> </tr> </thead> <tbody> <tr> <td>Inlet</td> <td>*13" (MIN. 4.5")</td> <td>17.4mb (MIN. 11.2mb)</td> <td>13" (MIN. 11")</td> <td>32.4mb (MIN. 27.4mb)</td> </tr> <tr> <td>Outlet</td> <td>3.5"</td> <td>8.7mb</td> <td>10"</td> <td>24.9mb</td> </tr> </tbody> </table> <p>*MAXIMUM INLET PRESSURE NOT TO EXCEED 13"</p>	Pressure	Natural Gas (inches)	Natural Gas (millibars)	Propane (inches)	Propane (millibars)	Inlet	*13" (MIN. 4.5")	17.4mb (MIN. 11.2mb)	13" (MIN. 11")	32.4mb (MIN. 27.4mb)	Outlet	3.5"	8.7mb
Pressure	Natural Gas (inches)	Natural Gas (millibars)	Propane (inches)	Propane (millibars)											
Inlet	*13" (MIN. 4.5")	17.4mb (MIN. 11.2mb)	13" (MIN. 11")	32.4mb (MIN. 27.4mb)											
Outlet	3.5"	8.7mb	10"	24.9mb											
Carbon is being deposited on glass, logs or combustion chamber surfaces.	Air shutter has become blocked.	<ul style="list-style-type: none"> - Ensure air shutter opening is free of lint or other obstructions. 													
	Flame is impinging on the logs or combustion chamber.	<ul style="list-style-type: none"> - Check that the logs are correctly positioned. - Open air shutter to increase the primary air. - Check the input rate: check the manifold pressure and orifice size as specified by the rating plate values. - Check that the door gasketing is not broken or missing and that the seal is tight. - Check that both vent liners are free of holes and well sealed at all joints. - Check that minimum rise per foot (meter) has been adhered to for any horizontal venting. 													
White / grey film forms.	Sulphur from fuel is being deposited on glass, logs or combustion chamber surfaces.	<ul style="list-style-type: none"> - Clean the glass with a recommended gas appliance glass cleaner. - DO NOT CLEAN GLASS WHEN HOT. - If deposits are not cleaned off regularly, the glass may become permanently marked. 													
Exhaust fumes smelled in room, headaches.	Appliance is spilling.	<ul style="list-style-type: none"> - Ensure exhaust bracket gasket seal. - Check door seal and relief flap seal. - Check for chimney blockage. - Check that chimney is installed to building code. - Room is in negative pressure; increase fresh air supply. - Check cap gasket on the flue pipe assembly. 													
Remote wall switch is in 'OFF' position; main burner comes on when gas knob is turned to 'ON' position.	Wall switch is mounted upside down.	<ul style="list-style-type: none"> - Reverse. 													
	Remote wall switch is grounding.	<ul style="list-style-type: none"> - Replace. 													
	Remote wall switch wire is grounding.	<ul style="list-style-type: none"> - Check for ground (short); repair ground or replace wire. 													
	Faulty valve.	<ul style="list-style-type: none"> - Replace. 													

17.0 warranty

Continental® products are manufactured under the strict standard of the world recognized ISO 9001 : 2015 Quality Management System.

Continental® products are designed with superior components and materials assembled by trained craftsmen who take great pride in their work. The burner and valve assembly are leak and test-fired at a quality test station. The complete appliance is again thoroughly inspected by a qualified technician before packaging to ensure that you, the customer, receives the quality product that you expect from Continental®.

Continental® Gas Appliance Limited Warranty

The following materials and workmanship in your new Continental® gas appliance are warranted against defects for a period of 5 years, this covers: combustion chamber, heat exchanger, stainless / steel burner, Phazer™ logs and embers, rocks, ceramic glass (thermal breakage only), gold plated parts against tarnishing, porcelainized enameled components and aluminum extrusion trims.*

Electrical (110V and millivolt) components and wearable parts are covered and Continental® will provide replacement parts free of charge during the first year of the limited warranty. This covers: blowers, gas valves, thermal switches, switches, wiring, remote controls, ignitors, gaskets and pilot assemblies.* Any labour related to warranty repair is not covered.

* Construction of models vary. Warranty applies only to components included with your specific appliance.

Conditions and Limitations

Continental® warrants its products against manufacturing defects to the original purchaser only. Registering your warranty is not necessary. Simply provide your proof of purchase along with the model and serial number to make a warranty claim. Continental® reserves the right to have its representative inspect any product or part thereof prior to honouring any warranty claim. Provided that the purchase was made through an authorized Continental® dealer your appliance is subject to the following conditions and limitations:

Warranty coverage begins on the date of original installation. This factory warranty is non-transferable and may not be extended whatsoever by any of our representatives. The gas appliance must be installed by a licensed, authorized service technician or contractor. Installation must be done in accordance with the installation instructions included with the product and all local and national building and fire codes. This limited warranty does not cover damages caused by misuse,

lack of maintenance, accident, alterations, abuse or neglect, and parts installed from other manufacturers will nullify this warranty. This limited warranty further does not cover any scratches, dents, corrosion or discoloring caused by excessive heat, abrasive and chemical cleaners nor chipping on porcelain enamel parts, mechanical breakage of Phazer™ logs and embers. In the first year only, this warranty extends to the repair or replacement of warranted parts which are defective in material or workmanship provided that the product has been operated in accordance with the operation instructions and under normal conditions. After the first year, with respect to this Limited Warranty, Continental® may, at its discretion, fully discharge all obligations with respect to this warranty by refunding to the original warranted purchaser the wholesale price of any warranted but defective part(s).

Continental® will not be responsible for installation, labour, or any other expenses related to the reinstallation of a warranted part and such expenses are not covered by this warranty. Notwithstanding any provisions contained in the Limited Warranty, Continental®'s responsibility under this warranty is defined as above and it shall not in any event extend to any incidental, consequential or indirect damages. This warranty defines the obligations and liability of Continental® with respect to the Continental® gas appliance and any other warranties expressed or implied with respect to this product, its components or accessories are excluded. Continental® neither assumes, nor authorizes any third party to assume, on its behalf, any other liabilities with respect to the sale of this product. Continental® will not be responsible for: over-firing, downdrafts, spillage caused by environmental conditions such as rooftops, buildings, nearby trees, hills, mountains, inadequate vents or ventilation, excessive venting configurations, insufficient makeup air, or negative air pressures which may or may not be caused by mechanical systems such as exhaust fans, furnaces, clothes dryers, etc. Any damages to the appliance, combustion chamber, heat exchanger, plated trim or other components due to water, weather damage, long periods of dampness, condensation, damaging chemicals or cleaners will not be the responsibility of Continental®. All parts replaced under the Limited Warranty Policy are subject to a single claim.

All parts replaced under the warranty will be covered for a period of 90 days from the date of their installation. The manufacturer may require that defective parts or products be returned or that digital pictures be provided to support the claim. Returned products are to be shipped prepaid to the manufacturer for investigation. If a product is found to be defective, the manufacturer will repair or replace such defect. Before shipping your appliance or defective components, your dealer must obtain an authorization number. Any merchandise shipped without authorization will be refused and returned to sender. Shipping costs are not covered under this warranty. Additional service fees may apply if you are seeking warranty service from a dealer. Labour, travel diagnostic tests, shipping and other related charges are not covered by this warranty.

All specifications and designs are subject to change without prior notice due to on-going product improvements. Continental® is a registered trademark of Wolf Steel Ltd.



7200, Route Transcanadienne, Montréal, Québec H4T 1A3
24 Napoleon Road, Barrie, Ontario, Canada L4M 0G8
214 Bayview Drive, Barrie, Ontario, Canada L4N 4Y8
103 Miller Drive, Crittenden, Kentucky, USA 41030

Phone: 1-866-820-8686
continentalfireplaces.com

